

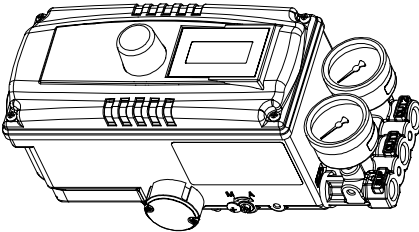

**YT-3300 (New NCS type)**



**YT-3350 (New NCS type)**



**YT-3300 + Internal Limit Switch  
(Potentiometer type)**

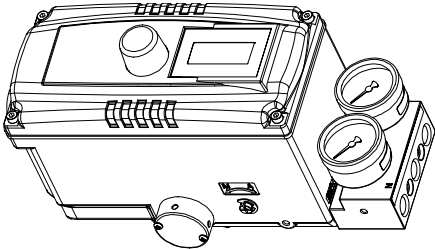

**YT-3350 + Internal Limit Switch  
(Potentiometer type)**



**YT-3303  
(Potentiometer type)**



**YT-3301  
(Potentiometer type)**

# ایمن کنترل سه‌هند

مرکز تخصصی طراحی، فروش و مشاوره

■ تجهیزات ابزار دقیق ■ تجهیزات ایمنی ■ تجهیزات ضد انفجار



Honeywell



آدرس: تهران - خیابان سمیه - بعد از تقاطع بهار - ساختمان ایرج - پلاک ۶۳ - واحد ۱۱

۰۹۳۹۵۱۸۸۱۶۴

۰۲۱-۸۸۳۴۱۴۸۳

۰۲۱-۸۶۰۷۲۸۲۳



IMEN  
CONTROL  
SAHAND

## Contents

<b>1</b>	<b>Introduction</b>	<b>6</b>
1.1	General Information for the users	6
1.2	Manufacturer Warranty	6
1.3	Explosion Proof Warning (Only for Intrinsic safety type positioners)	7
<b>2</b>	<b>Product Description</b>	<b>9</b>
2.1	General	9
2.2	Main Features and Functions	9
2.3	Label Description	10
2.4	Product Code	16
2.4.1	YT-3300 / 3350 series follows suffix symbols as follows	16
2.4.2	YT-3303 series follows suffix symbols as follows	17
2.4.3	YT-3301 series follows suffix symbols as follows	18
2.5	Product Specification	20
2.5.1	YT-3300 / 3303 / 3350 Specification	20
2.5.2	YT-3301 Specification	21
2.6	Certifications	22
2.7	Parts and Assembly	25
2.7.1	YT-3300 / 3350	25
2.7.2	YT-3303	26
2.7.3	YT-3301	27
2.8	Product Dimension	28
2.8.1	YT-3300	28
2.8.2	YT-3350	29
2.8.3	YT-3303	30
2.8.4	YT-3301	31
<b>3</b>	<b>Installation</b>	<b>32</b>
3.1	Safety	32
3.2	Tools for installation	32
3.3	Linear positioner Installation	33
3.3.1	Linear positioner Installation of Standard lever type	33
3.3.1.1	Safety	34
3.3.1.2	Standard lever type positioner Installation Steps	34
3.3.2	YT-3300L / 3350L Installation of Adapter lever type (on tubeless actuator)	39
3.3.2.1	Safety	39
3.3.2.2	Adapter lever type positioner Installation Steps	40
3.4	Rotary positioner Installation	42
3.4.1	YT-3300R / 3350R Components	42
3.4.2	YT-3303R Components	43
3.4.3	YT-3301R remote sensor components	43

3.4.4	Rotary Bracket Information (Only YT-3300R / 3350R / 3303R) .....	44
3.4.5	Rotary positioner Installation Steps .....	45
<b>4</b>	<b>Connection - Air .....</b>	<b>48</b>
4.1	Safety .....	48
4.2	Supply Pressure Condition .....	48
4.3	Piping Condition .....	48
4.4	Connection – Piping with actuator .....	49
4.4.1	Single acting actuator .....	49
4.4.2	Double acting actuator .....	50
<b>5</b>	<b>Connection – Power .....</b>	<b>51</b>
5.1	Safety .....	51
5.2	Connection .....	52
5.2.1	Standard Terminals .....	52
5.2.2	Terminals with micro-limit switch option .....	53
5.2.3	Terminals with inductive proximity Limit Switch option .....	54
5.3	Ground .....	55
<b>6</b>	<b>Adjustments .....</b>	<b>56</b>
6.1	Limit Switch Adjustment .....	56
6.2	A/M switch adjustment .....	57
6.3	Orifice Installment .....	58
6.3.1	Plate type Orifice Installment (except YT-3303) .....	58
6.3.2	Variable Orifice Adjustment (Only YT-3303) .....	58
<b>7</b>	<b>Optional Sub-PCB Installment .....</b>	<b>59</b>
7.1	Installation steps .....	59
<b>8</b>	<b>Maintenance .....</b>	<b>61</b>
8.1	Supply air .....	61
8.2	Seals .....	61
<b>9</b>	<b>Auto Calibration and PCB Operation .....</b>	<b>62</b>
9.1	Warning .....	62
9.2	LCD display and buttons .....	62
9.2.1	LCD display and symbols .....	62
9.2.2	Button and function .....	63
9.3	Menu levels .....	64
9.4	Run Mode (RUN) .....	65
9.5	Configuration and Operation .....	66
9.6	Calibration (CALib) .....	70
9.6.1	Acting Type (SINGLE / dDOUBLE) .....	70
9.6.2	Auto Calibration 1 (AUTO 1) .....	71
9.6.3	Auto Calibration 2 (AUTO 2) .....	71
9.6.4	Travel Zero (TVL ZERO) and Travel end (TVL END) .....	72

9.7	Manual Operation (MAN OPER).....	73
9.7.1	Manual Operation by Set position (MAN SP) .....	73
9.7.2	Manual Operation by Manipulator Value (MAN MV) .....	74
9.8	Control Parameters (CTL PARM).....	75
9.8.1	Dead Band (dEAdbANd).....	75
9.8.2	Forward P parameter (KP UP) and reverse P parameter (KP dN).....	76
9.8.3	Forward Integral time parameter (TI UP) and reverse Integral time parameter (TI dN).....	76
9.8.4	Forward D parameter (Kd UP) and reverse D parameter (Kd dN).....	77
9.8.5	GAP Parameter (GAP) .....	77
9.8.6	GAP P parameter (GP).....	78
9.8.7	GAP I parameter (GI).....	78
9.8.8	GAP D parameter (Gd) .....	78
9.8.9	Auto Dead band Mode (AUTO db) .....	79
9.8.10	Performance Mode (PER) .....	79
9.9	Input Configuration (IN CFG).....	80
9.9.1	Signal Direction (SIG NORM / REVS) .....	80
9.9.2	Split Range Mode (SPLIT).....	81
9.9.3	Custom Split Range Zero (CST ZERO).....	81
9.9.4	Custom Split Range End (CST ENd).....	82
9.9.5	Valve Flow Characterization Curves (CHAR).....	82
9.9.6	User Set Characterization 5 Points (U5) .....	83
9.9.7	User Set Characterization 21 Points (U21) .....	84
9.9.8	Tight Shut Open (TSHUT OP) .....	85
9.9.9	Tight Shut Close (TSHUT CL) .....	86
9.9.10	Target Position Ramp Up Rate (RAMP UP) and Target Position Ramp Down Rate (RAMP dN)	87
9.10	Output Configuration (OUT CFG).....	89
9.10.1	Position Transmitter Direction (PTM NORM / REVS).....	89
9.10.2	Position Transmitter Zero / End (PTM ZERO / ENd).....	90
9.10.3	HART Feedback Direction (HT NORM / REVS).....	91
9.10.4	Back Calculation (bACKCAL oFF / on).....	92
9.11	Device Configuration (dEV CFG).....	93
9.11.1	Action Setting (ACT REVS / dIR).....	93
9.11.2	Linear Lever Type (LEVT STd / AdT) .....	93
9.11.3	Linear Interpolation (ITP oFF / on).....	94
9.11.4	Lock of Parameters (Write Protect, W UNLOCK / LOCK) .....	94
9.11.5	Actual Position View Mode (View Mode, VI NORM / REVS) .....	95
9.11.6	Polling address setting (POL AddR).....	95
9.11.7	Factory Reset (dEFAULT oFF / on).....	96
9.11.8	Positioner Self-Test (SELFTTEST).....	97

---

9.12	Diagnosis Mode (dIAGNd).....	98
9.12.1	Default Alarm Settings .....	99
9.12.2	Process Status (PS) .....	100
9.12.3	Device Status (dS) .....	101
9.12.4	View Monitoring Counts (VI CNTS) .....	102
9.12.5	Diagnostic Limit Configuration (LIMT CFG).....	103
9.12.6	Reset Alarm Status (RST ALRM oFF / on).....	104
9.12.7	View Event Log (EVT LOG).....	105
9.12.8	Partial Stroke Test Record (View PST Result Record, PST RSLT) .....	106
9.12.9	PST Configuration (PST CFG) .....	107
9.12.10	Run PST (PST NOW) .....	108
9.12.11	Periodic PST Test (PST Schedule, PST SCHd oFF / on) .....	109
9.13	Position information (INFO) .....	109
9.14	Error codes during automatic calibration .....	111
9.15	Status and Alarm Code.....	112
<b>11</b>	<b>Main Software Map .....</b>	<b>114</b>

## 1 Introduction

### 1.1 General Information for the users

Thank you for purchasing Rotork YTC Limited products. Each product has been fully inspected after its production to offer you the highest quality and reliable performance. Please read the product manual carefully prior to installing and commissioning the product.

- Installation, commissioning, and maintenance of the product may only be performed by trained specialist personnel who have been authorized by the plant operator accordingly.
- The manual should be provided to the end-user.
- **Factory Mutual approved Intrinsically Safe and Non-Incendive units must be Installed Per drwg SKC\_18601\_150326.pdf**
- **CSA approved Intrinsically Safe and Non-Incendive units must be Installed Per drwg SKC-8465.pdf**
- The manual can be altered or revised without any prior notice. Any changes in product's specification, design, and/or any components may not be printed immediately but until the following revision of the manual.
- When the manual refers to "**Valve Zero / Zero**" means the final valve position upon pneumatic pressure has been fully exhausted from positioner's OUT1 port. For example, the valve zero position may differ between linear direct and reverse actions. (DA/RA)
- The manual should not be duplicated or reproduced for any purpose without prior approval from Rotork YTC Limited, Gimpo-si, South Korea.
- In case of any other problems that are not stated in this manual, please make immediate contact to Rotork YTC Limited.
- Positioner is an accessory of the control valve, so please make sure to read the applicable instruction manual of the control valve prior to installation and operation.

### 1.2 Manufacturer Warranty

- For the safety, it is important to follow the instructions in the manual. Manufacturer will not be responsible for any damages caused by user's negligence.
- Any modifications or repairs to the product may only be performed if expressed in this manual. Injuries and physical damages caused by customer's modifying or repairing the product without a prior consultation with Rotork YTC Limited will not be compensated. If any alterations or modifications are necessary, please contact Rotork YTC Limited directly.
- The warranty period of the product is (18) months from the date of shipment unless stated otherwise. Date of shipment can be checked by providing the LOT NO. or SERIAL NO. to us.

- Manufacturer warranty will not cover products that have been subjected to abuse, accidents, alterations, modifications, tampering, negligence, misuse, faulty installation, lack of reasonable care, repair or service in any way that is not contemplated in the documentation for the product, or if the model or serial number has been altered, tampered with, defaced or removed; damages that occurs in shipment, due to act of God, failure due to power surge, or cosmetic damage. Improper or incorrectly performed maintenance will void this limited warranty.
- For detailed warranty information, please contact the corresponding local Rotork YTC Limited office or main office in South Korea.

### 1.3 Explosion Proof Warning (Only for Intrinsic safety type positioners)

Please ensure the unit is being used and installed in conformity with local, regional, and national explosion proof within the proper safety barrier environment.

- Refer to “2.6 Certifications”
- Explosion proof type of cables and gaskets should be used, when explosion gases are present at the installation site.
- Positioner has 2 ports for power connection. Explosion proof type wires and packing should be used. Blind plug is required when any port is not being used.
- Ring terminal with surface area of more than 1.25 mm<sup>2</sup> with M4 spring washer should be used to connect the power.
- For external ground terminal, ring terminal with surface area of more than 5.5 mm<sup>2</sup> should be used.
- Wiring in these applications shall utilize appropriate methods for Class I, Division 2 / Zone 2
- Substitution of components may impair intrinsic safety.
- WARNING – EXPLOSION HAZARD – Substitution of components may impair suitability for Class I, Division 2.
- “AVERTISSEMENT – RISQUE D'EXPLOSION – Remplacement des composants peut nuire à la conformité de Classe I, Division 2”
- EXPLOSION HAZARD. Do not connect or disconnect wiring unless all sources of power have been removed or the area is known to be non-hazardous.  
(French) RISQUE D'EXPLOSION. Ne pas raccorder ou débrancher le câblage à moins Toutes les sources d'énergie ont été enlevées ou la zone est connue pour être non dangereux.
- The enclosure of models YT-3300, YT-3301, and YT-3303 contains aluminum, which is considered to constitute a potential risk of ignition when subjected to impact or friction. Care must be used during installation in locating this equipment to prevent impact or friction
- Some of the enclosure parts are made of non-metallic materials. To prevent the risk of Electrostatic sparking, clean the enclosure only with a damp cloth.
- The product must be installed in such a manner as to minimize the risk of impact or friction with other metal surfaces.



- For Intrinsically Safe installations, the product must be connected to suitably rated intrinsically safe equipment, and must be installed in accordance with applicable intrinsically safe installation standards.
- Special conditions for safe use :  
The ambient temperature range deviates from the standard temperature range and amounts to:  
Equipment must be protected from risk of mechanical impact hazard.  
  
Temperature class T5 / T100°C: -40°C to +60°C  
Temperature class T6 / T85°C: -40°C to +40°C
- FM & CSA only : Tapped Exhaust option is used when it is required to vent away Group D, Div/Group IIA, Zone gases to a safe area. Using gases other than air must be compatible with the YT-3300 series wetted parts.

## 2 Product Description

### 2.1 General

YT-3300 / 3350 / 3303 / 3301 series Smart Valve Positioner accurately controls valve stroke in response to an input signal of 4 ~ 20 mA from the controller. Built-in micro-processor optimizes the positioner's performance and provides unique functions such as **Auto-Calibration, PID Control, and HART Protocol Communications.**

### 2.2 Main Features and Functions

- LCD display enables users to monitor the positioner status.
- User will easily understand the method of using 4 buttons because it work same in all versions of firmware interfaces.
- When unexpected situation like momentary blackout happens, our positioner boot-time only take 0.5 second and this can minimize the travel of valve which consequentially increase the safety of system.
- Positioner operates normally even there are sudden changes in supply pressure and / or high vibration environment.
- YT-3301 remote positioner is stronger on high temperature and vibration environment because it is separated into remote sensor and positioner.
- The method of Auto Calibration is very simple.
- As an advantage of having very low air consumption, It could greatly reduce operating costs in large-scale plants.
- It is compatible with most of controllers.
- Orifices can be installed even in the field to minimize the hunting occurrence and optimize operating conditions.
- Various information about positioner can be processed by HART communication. (HART option)
- "EDD and FDI files required for HART communication can be downloaded from our website ([www.ytc.co.kr](http://www.ytc.co.kr)) or FieldComm Group ([www.fieldcommgroup.org](http://www.fieldcommgroup.org)). When using the FieldComm Group website, please search for the Product Name on YT-3XXX."
- Valve system becomes more stable by outputting analog feedback signal.
- Different valve characteristics can be adjusted – Linear, Quick Open, Equal Percentage, and User Set which user can make 5 or 18 points characterizations.
- Tight Shut – Close and Shut - Open can be set.
- PID parameters can be adjusted in the field without any additional communicator.
- A/M switch can be used to direct supply air to the actuator or to manually operate the positioner or valve without any signal.
- Split range 4 ~ 12 mA or 12 ~ 20 mA can be set.
- Operating temperature for remote sensor of YT-3301 is -40 ~ 120 °C.  
Operating temperature for positioners is -30 ~ 85 °C or -40 ~ 85 °C (Please check certified explosion proof temperature)

- Hand calibration function can set Zero point or End point manually.
- It has IP66, Type 4X(FM) protection grade.
- Polyester powder coating resists the corrosion process. (except YT-3350).
- Maintenance of the positioner is easy because of modularized inner structure.
- SIL2 certified.(For more information, see SIL Safety Instruction on homepage)
- Suitable for use with methane or natural gas supply pressure medium for FM/CSA (only A & AG of Explosion proof of Product code)
- The AG option in the product code has the tapped exhaust ports to carry the gas vented from the positioner to a safe location when the positioner is installed indoors to use methane or natural gas as a process medium.

### 2.3 Label Description

- MODEL : Indicates the model number and additional options.
- EXPLOSION PROOF : Indicates certified explosion proof grade.
- INGRESS PROTECTION : Indicates enclosure protection grade.
- INPUT SIGNAL : Indicates input signal range.
- OPERATING TEMP. : Indicates the allowable operating temperature.
- SUPPLY PRESSURE : Indicates the supply pressure range.
- SERIAL NUMBER : Indicates unique serial number.
- MONTH.YEAR : Indicates manufactured month and year.
  
- INTRINSIC SAFETY / NONINCENDIVE : Indicates intrinsic safety explosion proof grade.
- AMBIENT TEMP. : Indicates the allowable ambient temperature for explosion proof.
- Ui, li, Pi, Ci, Li : Indicates the allowable electrical data in the certificate.  
 ATEX: Ui = 28 V, li = 93 mA, Pi = 651 mW, Ci = 0.6 nF, Li = 10 μH  
 FM: Ui = 28 V, li = 93 mA, Pi = 651 mW, Ci = 0.55 nF, Li = 12 μH  
 You can also see the details in the certificate.

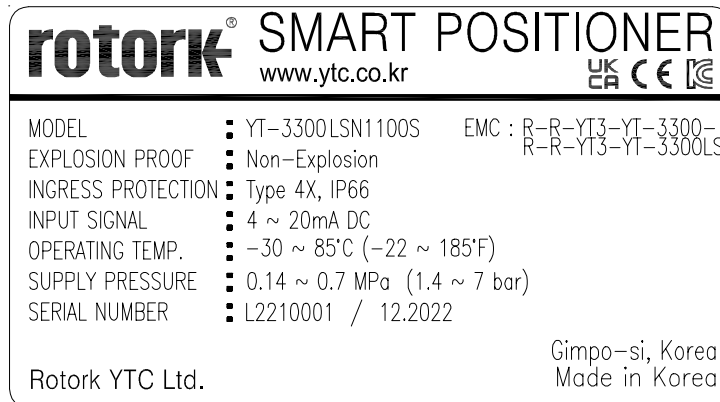

Fig. L-1: YT-3300 / 3303 / 3301 Non-explosion proof



Fig. L-2: YT-3300 Non-explosion proof (EAC)

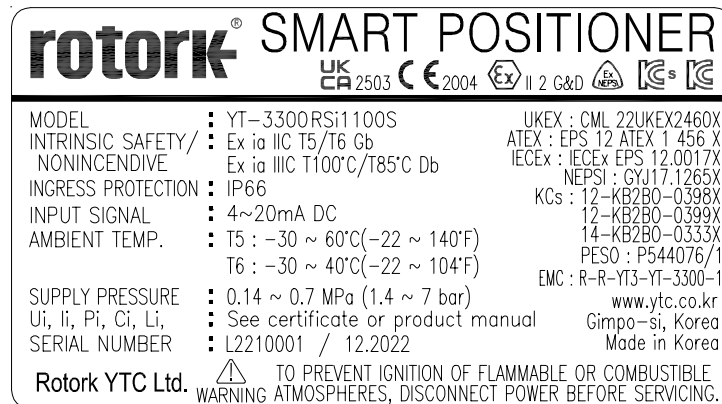

Fig. L-3: YT-3300 / 3301 / 3303 Intrinsic safety type (UKEX, ATEX, IECEx, KCs, NEPSI, PESO) (PESO applies only to YT-3300)



Fig. L-4: YT-3300 / 3303 Intrinsic safety type (FM, CSA)

    Rotork YTC Ltd. Gimpo-si, Korea www.ytc.co.kr Made in Korea	MODEL	YTC-3301 RDA1100S1	 * POTENTIAL ELECTROSTATIC CHARGING HAZARD :  SEE INSTRUCTIONS. WARNING * ПИСКЕ ПОТЕНТИЕЛ ДЕ ЧАРЖЕ ЕЛЕКТРОСТАТИКЕ. :  VOIR LES INSTRUCTIONS.
	INTRINSIC SAFETY/ NONINCENDIVE	Class I, Division 1&2, Grps ABCD T5/T6 Class II, Division 1&2, Grps EFG T100°C/T85°C; CI III Class I, Zone 0, AEx ia IIC T5/T6(FM) Ex ia IIC T5/T6 Ga; Ex tb IIIC T100°C/T85°C Db	
	INGRESS PROTECTION	Positioner : IP54, Feedback Sensor : Type 4X(FM), IP66	
	INPUT SIGNAL	4 ~ 20mA == DC	
	ELECTRICAL RATINGS	Rated 30 Vdc max, 100mA max, Class 2/SELV	
	AMBIENT TEMP.	T5 : -40 ~ 60°C / T6 : -40 ~ 40°C	
	ORD LOC OPERATING TEMP.	-30 ~ 85°C	
	SUPPLY PRESSURE	0.14 ~ 0.7 MPa (1.4 ~ 7 bar)	
	ENTITY/ NIFW PARAMETERS	FM : IS with Entity & NI per System Drawing SKC-18601_150326 CSA : IS with Entity per System Drawing SKC-8465	
	SERIAL NUMBER	L2210001 / 12.2022	

Fig. L-5: YT-3301 Intrinsic safety type (FM, CSA)

  УМНЫЙ ПОЗИЦИОНЕР  Gimpo-si, Korea Rotork YTC Ltd. www.ytc.co.kr Сделано в Корее		RU C-KR.AM02.B.00043/19	
		Модель Взрывозащищенный	YTC-3300 RDi1100L 1Ex ia IIC T6/T5 Gb X Ex ia IIIC T85°C/T100°C Db X
		Степень защиты	IP66
		Входной сигнал	4 ~ 20mA DC
		Окр. Темп.	T5 : -40 to 60°C(-40 to 140°F) T6 : -40 to 40°C(-40 to 104°F)
		Макс. раб. давл.	0,14 ~ 0,7 МПа (1,4 ~ 7 бар)
		Ui, II, Pi, Ci, Li,	См сертификат
		Серийный номер	C2110001 / 03.2021

Fig. L-6: YT-3300 / 3303 / 3301 Intrinsic safety type (EAC)





 SMART POSITIONER www.ytc.co.kr	NÚMERO DO MODELO	YTC-3300 LSi1100S	   DNV 17.0070 X
	MARCAÇÃO	Ex ia IIC T5/T6 Gb Ex ia IIIC T100°C/T85°C Db	
	GRAU DE PROTEÇÃO	IP66	
	SINAL DE ENTRADA	4~20mA	
	TEMPERATURA AMBIENTE	T5 : -30 ~ 60°C(-22 ~ 140°F) T6 : -30 ~ 40°C(-22 ~ 104°F)	
	PRESSÃO DE ALIMENTAÇÃO	0.14 ~ 0.7 MPa (1.4 ~ 7 bar)	
	Ui, II, Pi, Ci, Li,	See certificate or product manual	
	NÚMERO DE SÉRIE	L2210001 / 12.2022	
	Rotork YTC Ltd.	Gimpo-si, Korea Made in Korea	

Fig. L-7: YT-3300 / 3303 / 3301 Intrinsic safety type (INMETRO)

<b>rotork® 智能阀门定位器</b>		CCC	UK CA 2503	CE 2004	Ex II 2 G&D
www.ytc.co.kr					
型号	YT-3300LSZ1100S				
本安/非易燃	Ex ia IIC T5/T6 Gb, Ex iaD 21 T100/T85 NEPSI : GYJ17.1265X Ex ia IIIC T100°C/T85°C Db UKEX : CML 22UKEX2460X				
防护等级	IP66 ATEX : EPS 12 ATEX 1 456 X				
输入信号	4~20mA DC IECEX : IECEX EPS 12.0017X				
防爆环境温度	T5 : -40 ~ 60°C(-40~140°F) KCs : 12-KB2BO-0398X T6 : -40 ~ 40°C(-40~104°F) 12-KB2BO-0399X 14-KB2BO-0333X				
供给压力	0.14 ~ 0.7 MPa (1.4 ~ 7 bar)				
工作温度(不防爆型)	-30 ~ 85°C (-22 ~ 185°F) EMC : R-R-YT3-YT-3300-1				
Ui, li, Pi, Ci, Li,	请参阅证书或产品手册 金浦市, 韩国				
序列号	L2210001 / 12.2022 韩国制造				
Rotork YTC Ltd.	警告 为防止点燃易燃或可燃气体, 请在维修之前断开电源。				

Fig. L-8: YT-3300 Intrinsic safety type (CCC)

<b>rotork® 智能阀门定位器</b>		CCC	CE 2004	Ex II 2 G&D	IEC
www.ytc.co.kr					
型号	YT-3303 RSZ1100L				
本安/非易燃	Ex ia IIC T5/T6 Gb, Ex iaD 21 T100/T85 Ex ia IIIC T100°C/T85°C Db ATEX : EPS 12 ATEX 1 456 X				
防护等级	IP66 IECEX : IECEX EPS 12.0017X				
输入信号	4~20mA DC KCs : 14-KB2BO-0335X				
防爆环境温度	T5 : -40 ~ 60°C(-40~140°F) T6 : -40 ~ 40°C(-40~104°F)				
供给压力	0.14 ~ 0.7 MPa (1.4 ~ 7 bar)				
工作温度(不防爆型)	-40 ~ 85°C(-40~185°F)				
Ui, li, Pi, Ci, Li,	请参阅证书或产品手册 金浦市, 韩国				
序列号	C2110001 / 03.2021 韩国制造				
Rotork YTC Ltd.	警告 为防止点燃易燃或可燃气体, 请在维修之前断开电源。				

Fig. L-9: YT-3303 Intrinsic safety type (CCC)

<b>rotork® 智能阀门定位器</b>		CCC	UK CA 2503	CE 2004	Ex II 2 G&D
www.ytc.co.kr					
型号	YT-3300LSZ1100S				
本安/非易燃	Ex ia IIC T5/T6 Gb, Ex iaD 21 T100/T85 NEPSI : GYJ17.1265X Ex ia IIIC T100°C/T85°C Db UKEX : CML 22UKEX2460X				
防护等级	IP66 ATEX : EPS 12 ATEX 1 456 X				
输入信号	4~20mA DC IECEX : IECEX EPS 12.0017X				
防爆环境温度	T5 : -40 ~ 60°C(-40~140°F) KCs : 12-KB2BO-0398X T6 : -40 ~ 40°C(-40~104°F) 12-KB2BO-0399X 14-KB2BO-0333X				
供给压力	0.14 ~ 0.7 MPa (1.4 ~ 7 bar)				
工作温度(不防爆型)	-30 ~ 85°C (-22 ~ 185°F) EMC : R-R-YT3-YT-3300-1				
Ui, li, Pi, Ci, Li,	请参阅证书或产品手册 金浦市, 韩国				
序列号	L2210001 / 12.2022 韩国制造				
Rotork YTC Ltd.	警告 为防止点燃易燃或可燃气体, 请在维修之前断开电源。				

Fig. L-10: YT-3301 Intrinsic safety type (CCC)

<b>rotork®</b>		<b>SMART POSITIONER</b>	
www.ytc.co.kr		UK CA CE	
MODEL	YT-3350 RSN1100S		
EXPLOSION PROOF	Non-Explosion		
INGRESS PROTECTION	Type 4X, IP66		
INPUT SIGNAL	4 ~ 20mA DC		
OPERATING TEMP.	-30 ~ 85°C (-22 ~ 185°F)		
SUPPLY PRESSURE	0.14 ~ 0.7 MPa (1.4 ~ 7 bar)		
SERIAL NUMBER	L2210001 / 12.2022		
Rotork YTC Ltd.		Gimpo-si, Korea Made in Korea	

Fig. L-11: YT-3350 Non-explosion proof

<b>rotork®</b>		<b>SMART POSITIONER</b>	
www.ytc.co.kr		UK CA 2503 CE 2004 Ex II 2 G&D Ex NEPSI KCs	
MODEL	YT-3350 RSI1100S	UKEX	CML 22UKEX2460X
INTRINSIC SAFETY/	Ex ia IIC T5/T6 Gb	EPS	12 ATEX 1 456 X
NONINCENDIVE	Ex ia IIIC T100°C/T85°C Db	IECEX	EPS 12.0017X
INGRESS PROTECTION	IP66	NEPSI	GYJ17.1265X
INPUT SIGNAL	4 ~ 20mA DC	KCs	12-KB2B0-0402X
AMBIENT TEMP.	T5 : -30 ~ 60°C (-22 ~ 140°F)		12-KB2B0-0401X
	T6 : -30 ~ 40°C (-22 ~ 104°F)		14-KB2B0-0334X
SUPPLY PRESSURE	0.14 ~ 0.7 MPa (1.4 ~ 7 bar)		
Ui, li, Pi, Ci, Li	See certificate or product manual		
SERIAL NUMBER	L2210001 / 12.2022		
Rotork YTC Ltd.	⚠️ TO PREVENT IGNITION OF FLAMMABLE OR COMBUSTIBLE ATMOSPHERES, DISCONNECT POWER BEFORE SERVICING.		Gimpo-si, Korea Made in Korea

Fig. L-12: YT-3350 Intrinsic safety type (UKEX, ATEX, IECEX, KCs, NEPSI)

<b>rotork®</b>		<b>SMART POSITIONER</b>	
www.ytc.co.kr		FM CSA	
MODEL	YT-3350 RDA1100S		
INTRINSIC SAFETY/	Class I, Division 1&2, Grps ABCD T5/T6		
NONINCENDIVE	Class II, III, Division 1&2, Grps EFG T100°C/T85°C; CI III		
	Class I, Zone 0, AEx ia IIC T5/T6(FM)		
	Ex ia IIC T5/T6 Ga; Ex tb IIIC T100°C/T85°C Db		
INGRESS PROTECTION	Type 4X(FM), IP66		CSA 17.70131426.X Exia / 227951
INPUT SIGNAL	4 ~ 20mA DC		
ELECTRICAL RATINGS	Rated 30 Vdc max, 100mA max, Class 2/SELV		
AMBIENT TEMP.	T5 : -40 ~ 60°C / T6 : -40 ~ 40°C		
ORD LOC OPERATING TEMP.	-30 ~ 85°C		
SUPPLY PRESSURE	0.14 ~ 0.7 MPa (1.4 ~ 7 bar)		
ENTITY/	FM : IS with Entity & NI per System Drawing SKC-18601_150326		
NIFW PARAMETERS	CSA : IS with Entity per System Drawing SKC-8465		
SERIAL NUMBER	L2210001 / 12.2022		
Rotork YTC Ltd.	⚠️ * POTENTIAL ELECTROSTATIC CHARGING HAZARD : ⚠️ SEE INSTRUCTIONS. * PISQUE POTENTIEL DE CHARGE ELECTROSTATIQUE. : ⚠️ VOIR LES INSTRUCTIONS.		

Fig. L-13: YT-3350 Intrinsic safety type (FM, CSA)

<b>rotork®</b>		<b>Ex EAC</b>	RU C-KR.AM02.B.00043/19
УМНЫЙ ПОЗИЦИОНЕР		Модель	YT-3350 RSE1320L
○		Взрывозащищенный	0Ex ia IIC T6/T5 Ga X Ex ia IIIc T85°C/T100°C Da X
Gimpo-si, Korea Rotork YTC Ltd. www.ytc.co.kr Сделано в Корее		Степень защиты	IP66
		Входной сигнал	4 ~ 20mA DC
		Окр. Темп.	T5 : -40 to 60°C(-40 to 140°F) T6 : -40 to 40°C(-40 to 104°F)
		Макс. раб. давл.	0,14 ~ 0,7 МПа (1,4 ~ 7 бар)
		Ui, II, PI, Ci, Li,	См сертификат
		Серийный номер	C2110001 / 03.2021
			○

Fig. L-14: YT-3350 Intrinsic safety type (EAC)

<b>rotork®</b>		<b>SMART POSITIONER</b>	
		www.ytc.co.kr	
NÚMERO DO MODELO À PROVA DE EXPLOÇÃO		YT-3350 RS1132S00	
○		Ex ia IIC T5/T6 Gb Ex ia IIIc T100°C/T85°C Db	
PROTEÇÃO DE INGRESSO		IP66	○
SINAL DE ENTRADA		4~20 mA	
TEMPERATURA AMBIENTE		T5 : -30 ~ 60°C(-22 ~ 140°F) T6 : -30 ~ 40°C(-22 ~ 104°F)	
PRESSÃO DE ALIMENTAÇÃO		0.14 ~ 0.7 MPa (1.4 ~ 7 bar)	
Ui, II, PI, Ci, Li,		See certificate or product manual	
NÚMERO DE SÉRIE		L2210001 / 12.2022	
Rotork YTC Ltd.		Gimpo-si, Korea Made in Korea	

Fig. L-15: YT-3350 Intrinsic safety type (INMETRO)

<b>rotork®</b>		<b>智能阀门定位器</b>			
		www.ytc.co.kr			
型号		YT-3350 RSZ1100S	NEPSI : GYJ17.1265X		
本安/非易燃		Ex ia IIC T5/T6 Gb, Ex iaD 21 T100/T85 Ex ia IIIc T100°C/T85°C Db	KCs : 12-KB2BO-0402X 12-KB2BO-0401X 14-KB2BO-0334X		
○		防护等级	IP66		
		输入信号	4 ~ 20mA DC		
		防爆环境温度	T5 : -40 ~ 60°C(-40~140°F) / T6 : -40 ~ 40°C(-40~104°F)		
		供给压力	0.14 ~ 0.7 MPa (1.4 ~ 7 bar)	UKEX : CML 22UKEX2460X	
		工作温度(不防爆型)	-30 ~ 85°C (-22 ~ 185°F)	ATEX : EPS 12 ATEX 1 456 X	
		Ui, II, PI, Ci, Li, :	请参阅证书或产品手册	IECEX : IECEX EPS 12.0017X	
		序列号	L2210001 / 12.2022		
Rotork YTC Ltd.		警告 为防止点燃易燃或可燃气体, 请在维修之前断开电源。		金浦市, 韩国 韩国制造	

Fig. L-16: YT-3350 Intrinsic safety type (CCC)

2.4 Product Code

2.4.1 YT-3300 / 3350 series follows suffix symbols as follows.

YT-3300 / 3350 1 2 3 4 5 6 7 8

<span style="border: 1px solid black; padding: 2px 5px;">1</span>	Motion Type	L : Linear (Positioner is attached the right yoke of actuator.) R : Rotary				
<span style="border: 1px solid black; padding: 2px 5px;">2</span>	Acting type	S : Single D : Double				
<span style="border: 1px solid black; padding: 2px 5px;">3</span>	Explosion Proof	<sup>1)</sup> N : Non-Explosion <sup>i</sup> : ATEX, IECEx, KCs, NEPSI, INMETRO <sup>2)</sup> , UKEX, , PESO <sup>10)</sup> : Ex ia IIC T5/T6 Gb, Ex iaD IIIC T100°C/T85°C Db, IP66 <sup>1)</sup> A : FM, CSA : Class I, Division 1&2 Groups ABCD T5/T6 Class II, Division 1&2 Groups EFG T100°C/T85°C; Class III Class I, Zone 0, AEx ia IIC T5/T6(FM) Ex ia IIC T5/T6 Ga; Ex tb IIIC T100°C/T85°C Db <sup>12)</sup> AG : FM, CSA + Tapped Exhaust E : Intrinsic safety for EAC Z : Intrinsic safety for CCC				
<span style="border: 1px solid black; padding: 2px 5px;">4</span>	Lever Type	<table border="0" style="width: 100%;"> <tr> <td style="width: 15%; text-align: center;">Linear</td> <td>           0 : 10 ~ 40 mm (Standard type)            1 : 20 ~ 100 mm (Standard type)            2 : 90 ~ 150 mm (Standard type)            3 : 16 ~ 30 mm (Adapter type)            4 : 16 ~ 60 mm (Adapter type)            5 : 16 ~ 100 mm (Adapter type)            6 : 90 ~ 150 mm (Adapter type)         </td> </tr> <tr> <td style="text-align: center;">Rotary</td> <td>           1 : M6 x 34L            2 : M6 x 63L            3 : M8 x 34L            4 : M8 x 63L            5 : Namur         </td> </tr> </table>	Linear	0 : 10 ~ 40 mm (Standard type) 1 : 20 ~ 100 mm (Standard type) 2 : 90 ~ 150 mm (Standard type) 3 : 16 ~ 30 mm (Adapter type) 4 : 16 ~ 60 mm (Adapter type) 5 : 16 ~ 100 mm (Adapter type) 6 : 90 ~ 150 mm (Adapter type)	Rotary	1 : M6 x 34L 2 : M6 x 63L 3 : M8 x 34L 4 : M8 x 63L 5 : Namur
Linear	0 : 10 ~ 40 mm (Standard type) 1 : 20 ~ 100 mm (Standard type) 2 : 90 ~ 150 mm (Standard type) 3 : 16 ~ 30 mm (Adapter type) 4 : 16 ~ 60 mm (Adapter type) 5 : 16 ~ 100 mm (Adapter type) 6 : 90 ~ 150 mm (Adapter type)					
Rotary	1 : M6 x 34L 2 : M6 x 63L 3 : M8 x 34L 4 : M8 x 63L 5 : Namur					
<span style="border: 1px solid black; padding: 2px 5px;">5</span>	Conduit - Air Connection Type	1 : G 1/2 – Rc 1/4 2 : G 1/2 – 1/4 NPT (YT-3350 is available for No. 2 ONLY) 3 : G 1/2 – G 1/4 4 : M20x1.5P – 1/4 NPT 5 : 1/2 NPT – 1/4 NPT				
<span style="border: 1px solid black; padding: 2px 5px;">6</span>	Communication	0 : None 2 : + HART Communication				

	0 : None <sup>8)</sup>
	1 : + Position Transmitter <sup>9)</sup>
	2 : + Limit Switch(Mechanical Type) <sup>3)</sup>
<b>7</b> Option	3 : + Limit Switch(Inductive Proximity Type) <sup>4)</sup>
	4 : + Position Transmitter and Limit Switch (Mechanical Type) <sup>5)</sup>
	5 : + Position Transmitter and Limit Switch (Inductive Proximity Type) <sup>6)</sup>
<b>8</b> Operating Temp. (Non-explosion proof) <sup>7)</sup>	S : -30 ~ 85 °C (-22 ~ 185 °F, except EAC)
	L : -40 ~ 85 °C (-40 ~ 185 °F)
	A : -55 ~ 85 °C (-67 ~ 185 °F, only EAC)

- <sup>1)</sup> In case of EAC non-explosion type, put "EAC" in a purchase order.
- <sup>2)</sup> In case of INMETRO, put "INMETRO" in a purchase order.
- <sup>3) 5)</sup> These options are only available for "S", "L" in **8** operating temp.
- <sup>4) 6)</sup> These options are only available for "S" in **8** operating temp.
- <sup>7)</sup> This option is just the normal operating temperature of the product and is not related to explosion proof temperature. See "2.6 Certificates" for explosion proof temperature.
- <sup>8) 9)</sup> NCS type
- <sup>3) 4) 5) 6) 11) 12)</sup> Potentiometer type
- <sup>10)</sup> PESO applies only to YT-3300.

2.4.2 YT-3303 series follows suffix symbols as follows.

(YT-3303 has only a potentiometer type)

YT-3303 **1** **2** **3** **4** **5** **6** **7** **8**

<b>1</b> Motion Type	L : Linear (Positioner is attached the left yoke of actuator.) R : Rotary
<b>2</b> Acting type	S : Single D : Double
<b>3</b> Explosion Proof	N : Non-Explosion i : ATEX, IECEx, KCs, NEPSI, INMETRO <sup>1)</sup> , UKEX : Ex ia IIC T5/T6 Gb, Ex iaD IIIC T100°C/T85°C Db, IP66 A : FM, CSA : Class I, Division 1&2 Groups ABCD T5/T6 Class II, Division 1&2 Groups EFG T100°C/T85°C; Class III Class I, Zone 0, AEx ia IIC T5/T6(FM) Ex ia IIC T5/T6 Ga; Ex tb IIIC T100°C/T85°C Db AG : FM, CSA + Tapped Exhaust E : Intrinsic safety for EAC Z : Intrinsic safety for CCC

4	Lever Type	Linear	1 : 10 ~ 40 mm 2 : 20 ~ 70 mm 3 : 50 ~ 100 mm 4 : 100 ~ 150 mm
		Rotary	1 : M6 x 34L 2 : M6 x 63L 3 : M8 x 34L 4 : M8 x 63L 5 : Namur
5	Conduit – Air Connection Type		1 : G 1/2 – Rc 1/4 2 : G 1/2 – 1/4 NPT 3 : G 1/2 – G 1/4 4 : M20x1.5P(Adapter type) – 1/4 NPT 5 : 1/2 NPT(Adapter type) – 1/4 NPT
6	Communication		0 : None 2 : + HART Communication
7	Option		0 : None 1 : + Position Transmitter
8	Operating Temp. (Non-explosion proof) <sup>2)</sup>	S :	-30 ~ 85 °C (-22 ~ 185 °F, except EAC)
		L :	-40 ~ 85 °C (-40 ~ 185 °F)
		A :	-55 ~ 85 °C (-67 ~ 185 °F, only EAC)

<sup>1)</sup> In case of INMETRO, put “INMETRO” in a purchase order sheet.

<sup>2)</sup> This option is just the normal operating temperature of the product and is not related to explosion proof temperature. See “2.6 Certificates” for explosion proof temperature.

2.4.3 YT-3301 series follows suffix symbols as follows.

(YT-3301 has only a potentiometer type)

YT-3301 1 2 3 4 5 6 7 8 9

1	Motion Type	L :	Linear
		R :	Rotary
2	Acting type	S :	Single
		D :	Double

		N : Non-Explosion i : ATEX, IECEx, KCs, NEPSI, INMETRO <sup>1)</sup> , UKEX : Ex ia IIC T5/T6 Gb, Ex iaD IIIC T100°C/T85°C Db, IP66 A : FM & CSA : Class I, Division 1&2 Groups ABCD T5/T6 Class II, Division 1&2 Groups EFG T100°C/T85°C; Class III Class I, Zone 0, AEx ia IIC T5/T6(FM) Ex ia IIC T5/T6 Ga; Ex tb IIIC T100°C/T85°C Db AG : FM, CSA + Tapped Exhaust E : Intrinsic safety for EAC Z : Intrinsic safety for CCC				
<b>3</b>	Explosion Proof					
<b>4</b>	Lever Type	<table border="1"> <tr> <td>Linear</td> <td>1 : 10 ~ 40 mm 2 : 20 ~ 70 mm 3 : 50 ~ 100 mm 4 : 100 ~ 150 mm</td> </tr> <tr> <td>Rotary</td> <td>5 : Namur</td> </tr> </table>	Linear	1 : 10 ~ 40 mm 2 : 20 ~ 70 mm 3 : 50 ~ 100 mm 4 : 100 ~ 150 mm	Rotary	5 : Namur
Linear	1 : 10 ~ 40 mm 2 : 20 ~ 70 mm 3 : 50 ~ 100 mm 4 : 100 ~ 150 mm					
Rotary	5 : Namur					
<b>5</b>	Conduit – Air Connection Type	1 : G 1/2 – Rc 1/4 2 : G 1/2 – 1/4 NPT 3 : G 1/2 – G 1/4 4 : M20x1.5P(Adapter type) – 1/4 NPT 5 : 1/2 NPT(Adapter type) – 1/4 NPT				
<b>6</b>	Communication	0 : None 2 : + HART Communication				
<b>7</b>	Option	0 : None 1 : + Position Transmitter				
<b>8</b>	Operating Temp. (Non-explosion proof) <sup>2)</sup>	S : -30 ~ 85 °C (-22 ~ 185 °F, except EAC) L : -40 ~ 85 °C (-40 ~ 185 °F) A : -55 ~ 85 °C (-67 ~ 185 °F, only EAC)				
<b>9</b>	Cable Length <sup>3)</sup>	1 : 5m 2 : 10m 3 : 15m 4 : 20m				

<sup>1)</sup> In case of INMETRO, put “INMETRO” in a purchase order sheet.

<sup>2)</sup> Maximum cable length is 20m.

<sup>3)</sup> This option is just the normal operating temperature of the product and is not related to explosion proof temperature. See “2.6 Certificates” for explosion proof temperature.

2.5 Product Specification

2.5.1 YT-3300 / 3303 / 3350 Specification

Model		YT-3300 / 3303		YT-3350	
Housing Material		Aluminum		Stainless Steel 316	
Motion Type		Linear	Rotary	Linear	Rotary
Acting Type		Single / Double			
Input Signal		4 ~ 20 mA DC			
Minimum Current Signal		Standard : 3.6 mA (NCS type) / 3.2 mA (Potentiometer type) PTM Internal : 3.7 mA (NCS type) / 3.6 mA (Potentiometer type) HART or HART+PTM Internal : 3.8 mA			
Supply Pressure		0.14 ~ 0.7 MPa (1.4 ~ 7 bar)			
Stroke		10 ~ 150 mm	55 ~ 110°	10 ~ 150 mm	55 ~ 110°
Impedance		Max. 500 Ω @ 20 mA DC			
Air Connection		Rc 1/4 or 1/4 NPT or G 1/4		1/4 NPT	
Gauge Connection		Rc 1/8 or 1/8 NPT		1/8 NPT	
Conduit Entry		G 1/2 or 1/2 NPT or M20x1.5P		G 1/2	
Tapped Exhaust (Only AG option of Product code)		1/4 NPT			
Ingress Protection		IP66, Type 4X(FM)			
Explosion Proof		1. None-explosion proof 2. Intrinsic safety : UKEX, ATEX, IECEx, KCs, NEPSI, EAC, INMETRO, FM, CSA, CCC, PESO ※ See "2.6 Certificates" for details			
Operating Temperature	Standard Type	-30 ~ 85 °C (-22 ~ 185 °F) Inductive proximity limit switch internal type : -25 ~ 85 °C (-13 ~ 185 °F) Except EAC			
	Low Temp. Type	-40 ~ 85 °C (-40 ~ 185 °F)			
	Arctic Temp. Type	-55 ~ 85 °C (-67 ~ 185 °F, only EAC)			
Ambient Temperature Of Explosion Proof		T5	-40 ~ 60 °C (-40 ~ 140 °F) EAC : -55 ~ 60 °C (-67 ~ 140 °F)		
		T6	-40 ~ 40 °C (-40 ~ 104 °F) EAC : -55 ~ 40 °C (-67 ~ 104 °F)		
Linearity		± 0.5 % F.S.			
Hysteresis		± 0.5 % F.S.			
Sensitivity		± 0.2 % F.S.			
Repeatability		± 0.3 % F.S.			
Flow Capacity		70 LPM (Sup. = 0.14 MPa)			
Air Consumption		Below 2 LPM (Sup. = 0.14 MPa @ idle)			

<b>Output Characteristic</b>		Linear, Quick Open, EQ%, User Set	
<b>Vibration</b>		No Resonance up to 100 Hz @ 6 G	
<b>Humidity</b>		5 ~ 95 % RH @ 40 °C	
<b>Communication (Option)</b>		HART Communication (HART 7)	
<b>Feedback Signal (Option)</b>		4 ~ 20 mA (DC 9 ~ 28 V)	
<b>L/S Rating (Option) (Except YT-3303)</b>	<b>Mechanical</b>	AC 125 V 3 A / DC 30 V 2 A	
	<b>Inductive Proximity</b>	DC 8.2 V 8.2 mA	
<b>Weight</b>		2 kg (4.4 lb)	5.1 kg (11.2 lb)
<b>Painting</b>		Polyester Powder Coating	-



Tested under ambient temperature of 20 °C, absolute pressure of 760 mmHg, and humidity of 65 %.  
 Please contact Rotork YTC Limited for detailed testing specification.

2.5.2 YT-3301 Specification

<b>Model</b>		<b>YT-3301</b>	
<b>Housing Material</b>		Aluminum	
<b>Motion Type</b>		Linear	Rotary
<b>Acting Type</b>		Single / Double	
<b>Input Signal</b>		4 ~ 20 mA DC	
<b>Minimum Current Signal</b>		Standard : 3.2 mA PTM Internal : 3.6 mA HART or HART+PTM Internal : 3.8 mA	
<b>Supply Pressure</b>		0.14 ~ 0.7 MPa (1.4 ~ 7 bar)	
<b>Stroke</b>		10 ~ 150 mm	55 ~ 110°
<b>Impedance</b>		Max. 500 Ω @ 20 mA DC	
<b>Air Connection</b>		Rc 1/4 or 1/4 NPT or G 1/4	
<b>Gauge Connection</b>		Rc 1/8 or 1/8 NPT	
<b>Conduit Entry</b>		G 1/2 or 1/2 NPT or M20x1.5P	
<b>Tapped Exhaust (Only AG option of Product code)</b>		1/4 NPT	
<b>Ingress Protection</b>	<b>Positioner module</b>	IP54	
	<b>Feedback sensor</b>	IP66, Type 4X(FM)	
<b>Explosion Proof</b>		1. None-explosion proof 2. Intrinsic safety : ATEX, IECEx, KCs, NEPSI, EAC, INMETRO, FM, CSA, CCC, UKEX ※ See "2.6 Certificates" for details	
<b>Operating Temperature</b>	<b>Sensor</b>		-55 ~ 120 °C (-67 ~ 248 °F)
	<b>Body</b>	<b>Standard</b>	-30 ~ 85 °C (-22 ~ 185 °F, except EAC)
		<b>Low temp.</b>	-40 ~ 85 °C (-40 ~ 185 °F)
		<b>Arctic temp.</b>	-55 ~ 85 °C (-67 ~ 185 °F, only EAC)

<b>Ambient Temperature Of Explosion proof</b>	<b>T5</b>	-40 ~ 60 °C (-40 ~ 140 °F) EAC : -55 ~ 60 °C (-67 ~ 140 °F)	
	<b>T6</b>	-40 ~ 40 °C (-40 ~ 104 °F) EAC : -55 ~ 40 °C (-67 ~ 104 °F)	
<b>Linearity</b>		± 0.5 % F.S.	
<b>Hysteresis</b>		± 0.5 % F.S.	
<b>Sensitivity</b>		± 0.2 % F.S.	
<b>Repeatability</b>		± 0.3 % F.S.	
<b>Flow Capacity</b>		70 LPM (Sup. = 0.14 MPa)	
<b>Air Consumption</b>		Below 2 LPM (Sup. = 0.14 MPa @ idle)	
<b>Output Characteristic</b>		Linear, Quick Open, EQ%, User Set	
<b>Vibration</b>		No Resonance up to 100 Hz @ 6 G	
<b>Humidity</b>		5 ~ 95% RH @ 40 °C	
<b>Communication (Option)</b>		HART Communication (HART 7)	
<b>Feedback Signal (Option)</b>		4 ~ 20mA (DC 9 ~ 28 V)	
<b>Weight</b>	<b>Positioner</b>	2.2 kg (4.9 lb)	
	<b>Remote Sensor</b>	0.6 kg (1.2 lb)	1.0 kg (2.1 lb)
	<b>Cable(5M)</b>	0.6 kg (1.3 lb)	
<b>Painting</b>		Polyester Powder Coating	



Tested under ambient temperature of 20 °C, absolute pressure of 760 mmHg, and humidity of 65 %.  
Please contact Rotork YTC Limited for detailed testing specification.

## 2.6 Certifications

※ All certifications below are posted on Rotork YTC Limited homepage([www.ytc.co.kr](http://www.ytc.co.kr)).

### ➤ **KCs (Korea)**

Type : Intrinsic safety

Rating : Ex ia IIC T5/T6, Ex iaD T100°C/T85°C, IP66

Certification No. : 12-KB2BO-0398X(YT-3300)

12-KB2BO-0399X{YT-3300+LS(Dry contact)}

14-KB2BO-0333X{YT-3300+LS(Non-contact)}

12-KB2BO-0402X(YT-3350)

12-KB2BO-0401X{YT-3350+LS(Dry contact)}

14-KB2BO-0334X{YT-3350+LS(Non-contact)}

14-KB2BO-0335X(YT-3303)

12-KB2BO-0400X(YT-3301)

Ambient temperature : -40 ~ +60°C (T5/T100°C), -40 ~ +40°C (T6/T85°C)

### ➤ **ATEX**

Type : Intrinsic safety

Rating : II 2G Ex ia IIC T5/T6 Gb, II 2D Ex ia IIIC T100°C/T85°C Db, IP6X

Certification No. : EPS 12 ATEX 1 456 X

Ambient temperature : -40 ~ +60°C (T5), -40 ~ +40°C (T6)

- **IECEX**  
Type : Intrinsic safety  
Rating : Ex II 2G Ex ia IIC T5/T6 Gb, Ex II 2D Ex ia IIIC T100°C/T85°C Db, IP6X  
Certification No. : IECEx EPS 12.0017X  
Ambient temperature : -40 ~ +60°C (T5/T100°C), -40 ~ +40°C (T6/T85°C)
  
- **NEPSI**  
Type : Intrinsic safety  
Rating : Ex ia IIC T5/T6  
Certification No. : GYJ17.1265X
  
- **EAC (TRCU)**  
Type : Intrinsic safety  
Rating : 1Ex ia IIC «T6 ... T5» Gb X, Ex ia IIIC «T85°C ... T100°C» Db X  
Certification No. : RU C-KR.MIO62.B.04756  
Ambient temperature : -55 ~ +60°C (T5/T100°C), -55 ~ +40°C (T6/T85°C)
  
- **FM**  
Rating : Class I, Div 1, Groups ABCD  
Class I, Zone 0 AEx ia IIC  
Class II/III, Div 1, Groups EFG  
Class I, II, III, Div 2, Groups ABCDFG  
NEMA Type 4X, IP66  
(Only YT-3301: Positioner IP54, Feedback sensor Type 4X, IP66)  
Certificate No.: FM16US0268X  
Ambient temperature : -40 to +60°C(T5), -40 to +40°C(T6)
  
- **CSA**  
Type : Intrinsic safety  
Rating : Class I, Division 1&2 Groups ABCD T5/T6  
Class II, Division 1&2 Groups EFG T100°C/T85°C  
Class III  
Ex ia IIC T5/T6 Ga  
Ex tb IIIC T100°C/T85°C Db  
IP66  
Certificate No.: CSA 17.70131426  
Ambient temperature : -40 to +60°C(T5), -40 to +40°C(T6)
  
- **INMETRO(Brazil)**  
Type : Intrinsic safety  
Rating : Ex ia IIC T5/T6 Gb, Ex ia IIIC T100°C/T85°C Db, IP66  
Certification No. : DNV 17.0070 X  
Ambient temperature : -40 ~ +60°C (T5), -40 ~ +40°C (T6)
  
- **CCC (China)**  
Type : Intrinsic safety  
Rating : Ex ia IIC T5/T6 Gb, Ex iaD 21 T100/T85  
Certification No. : 20200322307000617  
Ambient temperature : -40 ~ +60°C (T5/T100°C), -40 ~ +40°C (T6/T85°C)

➤ **UKEX**

Type : Intrinsic safety

Rating : II 2G Ex ia IIC T5/T6 Gb, II 2D Ex ia IIIC T100°C/T85°C Db, IP6X

Certification No. : CML 22UKEX2460X

Ambient temperature : -40 ~ +60°C (T5), -40 ~ +40°C (T6)

➤ **PESO (India) : Only available for YT-3300**

Type : Intrinsic safety

Rating : Ex ia IIC T5/T6 Gb

Certification No. : P561217/1

Ambient temperature : -40 ~ +60°C (T5/T100°C), -40 ~ +40°C (T6/T85°C)

➤ **SIL2 (in a redundant structure up to SIL 3)**

Intended application : Safety function is defined as to move into fail-safe-position, when signal to positioner is interrupted.

Certification No. : 968/V 1155.00/20

➤ **Electromagnetic Compatibility (EMC)**

- EMC directive 2014/30/EC from April 2016

- EC Directive for CE conformity marking

2.7 Parts and Assembly

2.7.1 YT-3300 / 3350

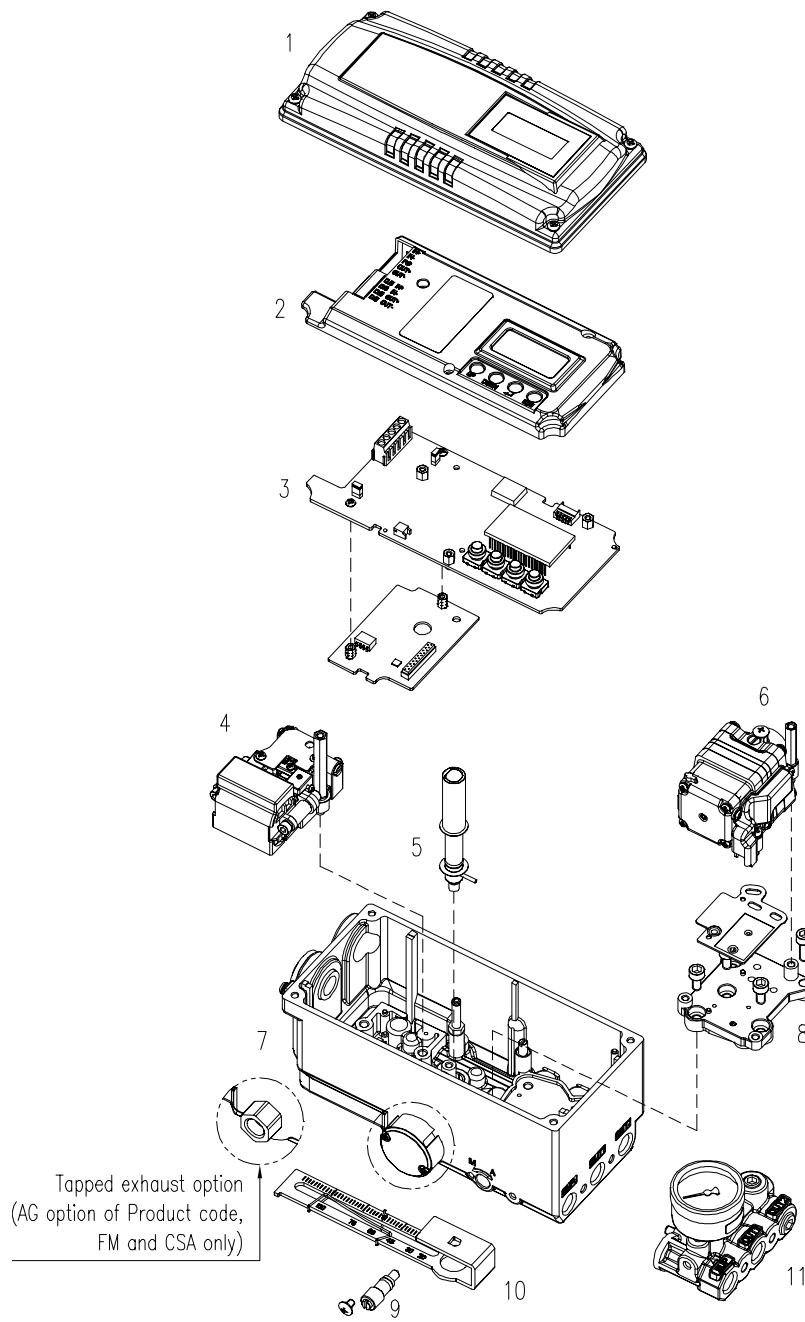

Fig. 2-1: YT-3300 / 3350 exploded view

- |                     |                       |
|---------------------|-----------------------|
| 1. Base Cover       | 7. Base body          |
| 2. PCB Cover        | 8. Pilot Block        |
| 3. Main PCB         | 9. Auto Manual Switch |
| 4. Torque Motor     | 10. Feedback Lever    |
| 5. Main Shaft (NCS) | 11. Gauge Block       |
| 6. Pilot            |                       |

2.7.2 YT-3303

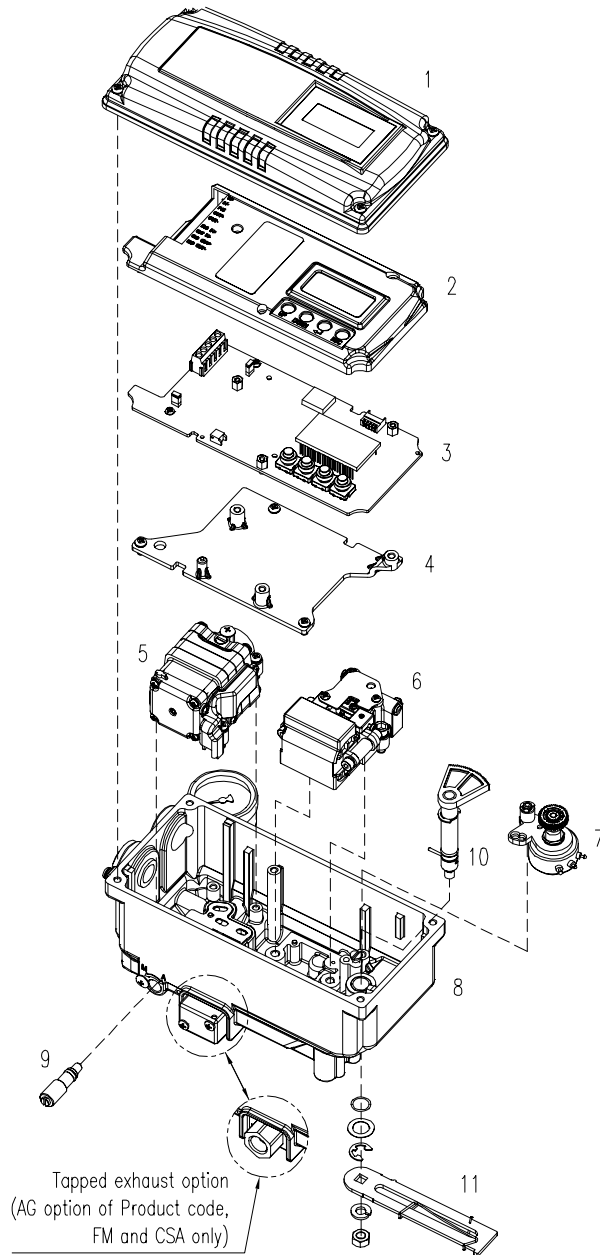

Fig. 2-2: YT-3303 exploded view

- |                 |                       |
|-----------------|-----------------------|
| 1. Base Cover   | 7. Potentiometer      |
| 2. PCB Cover    | 8. Base body          |
| 3. Main PCB     | 9. Auto Manual Switch |
| 4. Support PCB  | 10. Main Shaft        |
| 5. Pilot        | 11. Feedback Lever    |
| 6. Torque Motor |                       |

2.7.3 YT-3301

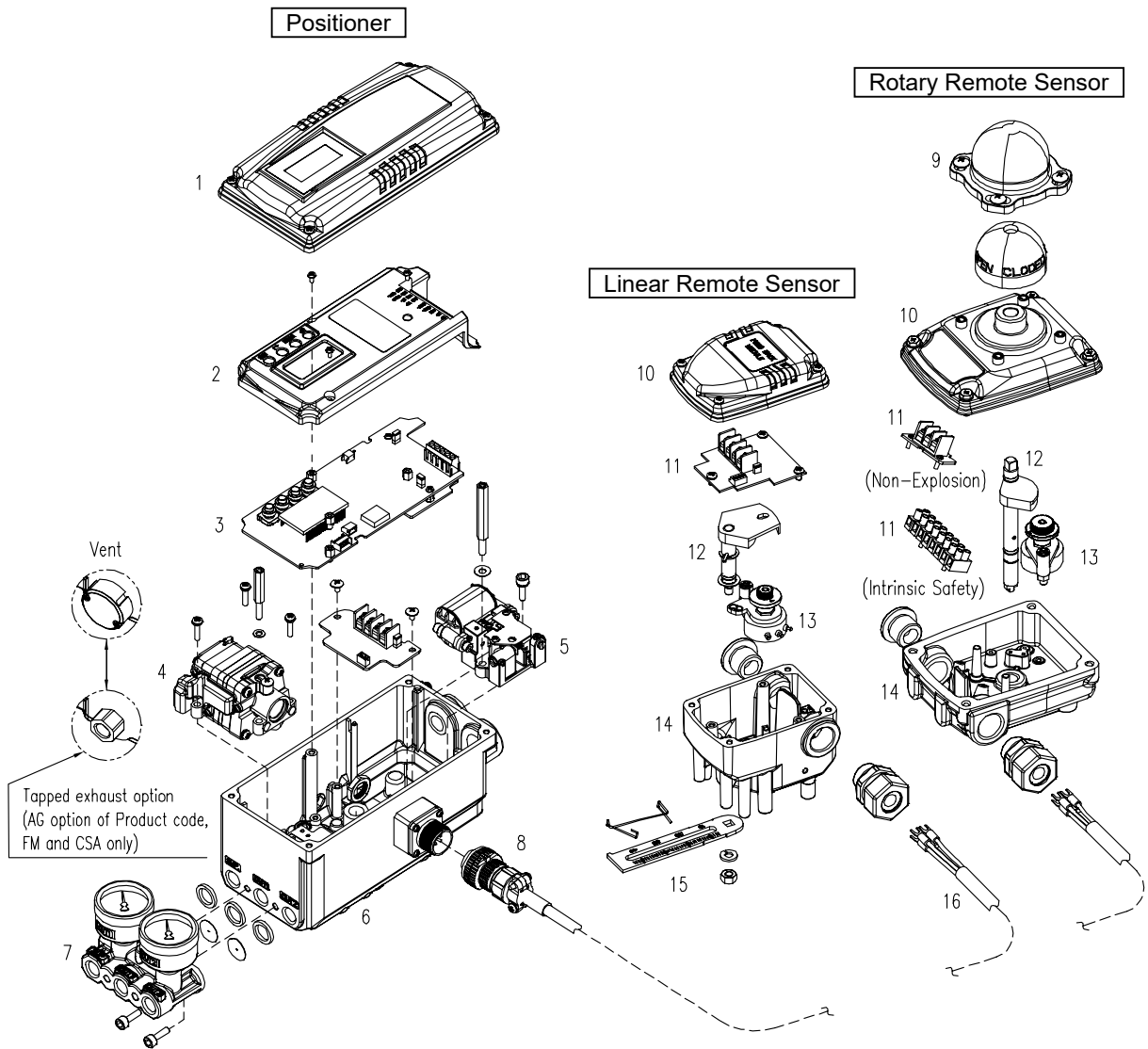

Fig. 2-3: YT-3301 exploded view

- |                               |                                    |
|-------------------------------|------------------------------------|
| 1. Base cover of Positioner   | 9. Dome cover of Remote sensor     |
| 2. PCB cover of Positioner    | 10. Base cover of Remote sensor    |
| 3. PCB of Positioner          | 11. Terminal of Remote sensor      |
| 4. Pilot of Positioner        | 12. Main shaft of Remote sensor    |
| 5. Torque motor of Positioner | 13. Potentiometer of Remote sensor |
| 6. Base body of Positioner    | 14. Base body of Remote sensor     |
| 7. Gauge block of Positioner  | 15. Lever of Remote sensor         |
| 8. MS connector of Positioner | 16. Remote cable                   |

2.8 Product Dimension

2.8.1 YT-3300

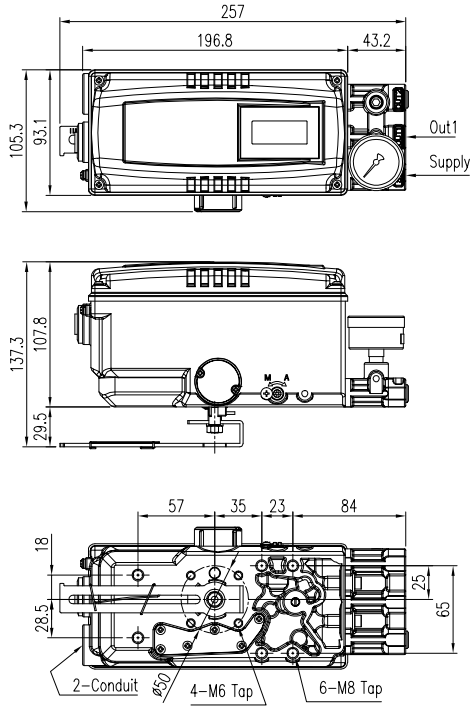

Fig. 2-4: YT-3300L (Standard Lever Type)

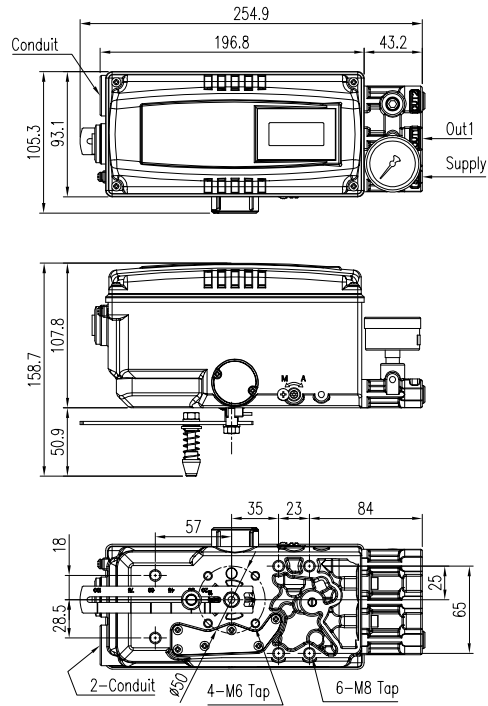

Fig. 2-5: YT-3300L (Adapter Lever Type)

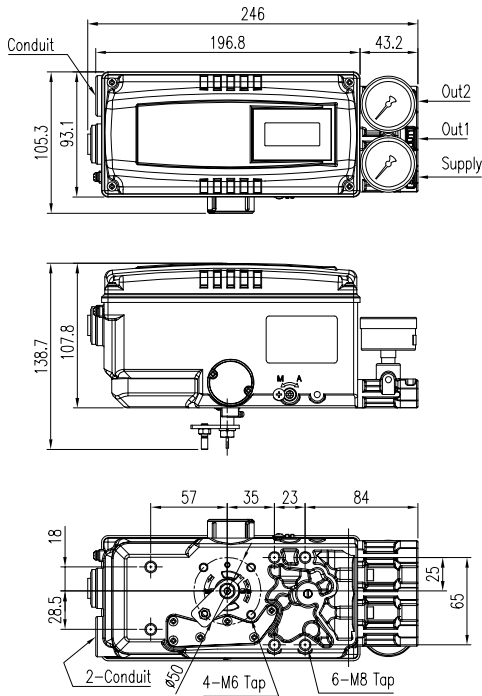

Fig. 2-6: YT-3300R (Fork lever Type)

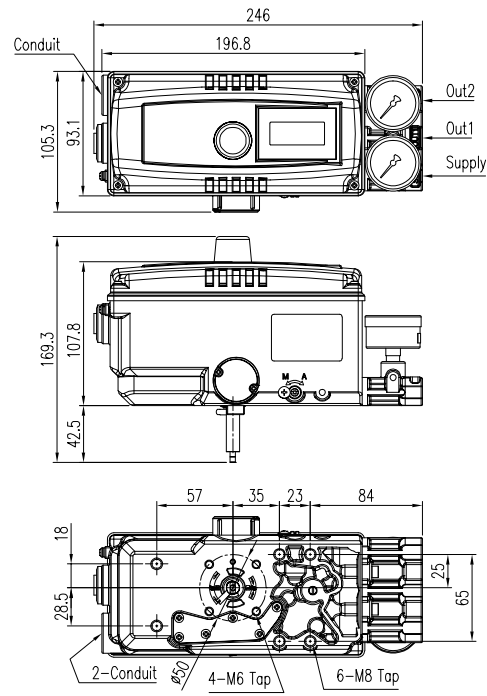

Fig. 2-7: YT-3300R+LS (Namur Type)

2.8.2 YT-3350

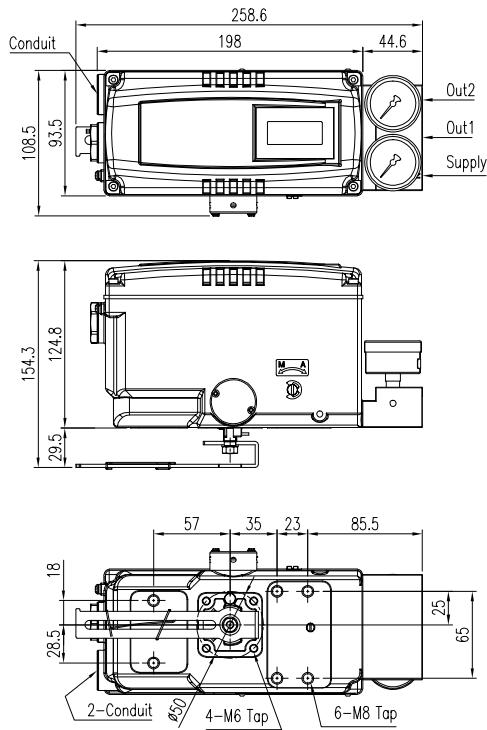

Fig. 2-8: YT-3350L (Standard Lever Type)

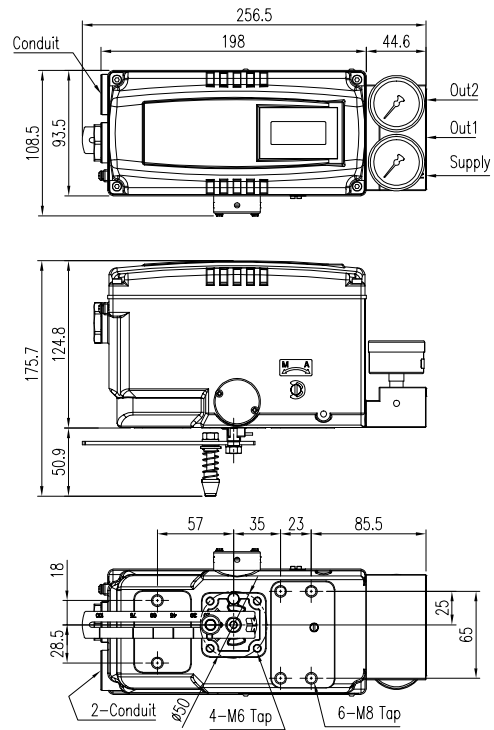

Fig. 2-9: YT-3350L (Adapter Lever Type)

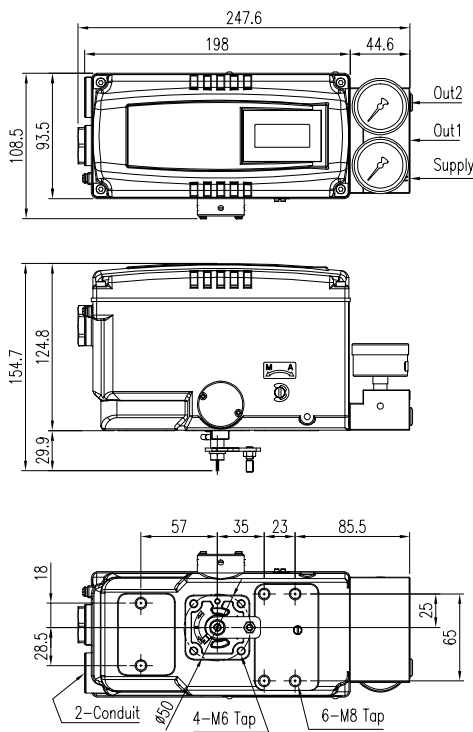

Fig. 2-10: YT-3350R (Fork lever Type)

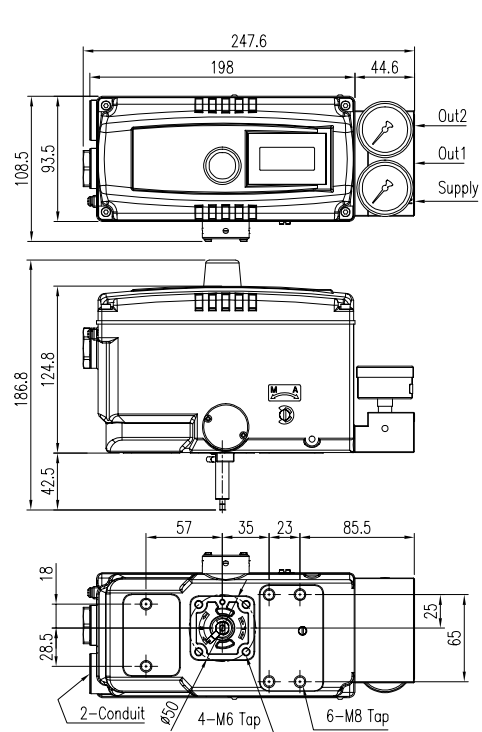

Fig. 2-11: YT-3350R+LS (Namur Type)

2.8.3 YT-3303

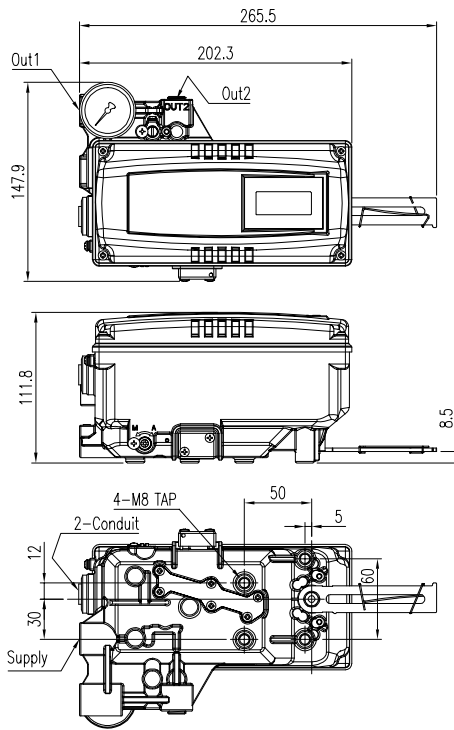

Fig. 2-12: YT-3303L

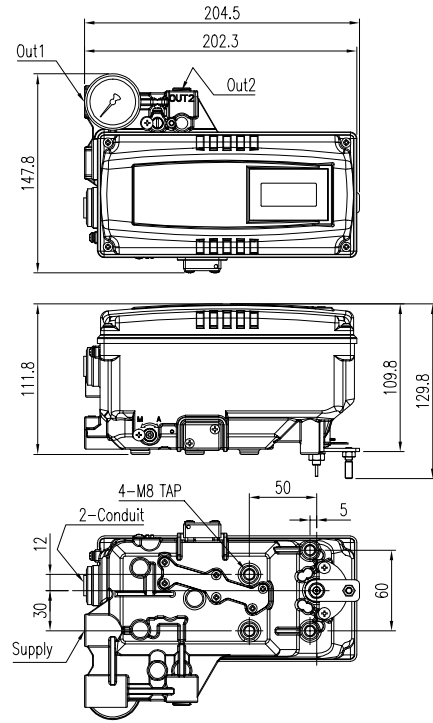

Fig. 2-13: YT-3303R (Fork lever Type)

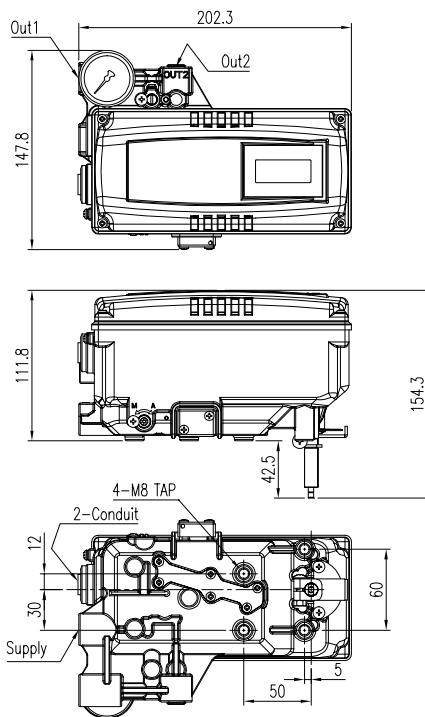

Fig. 2-14: YT-3300R+LS (Namur Type)

2.8.4 YT-3301

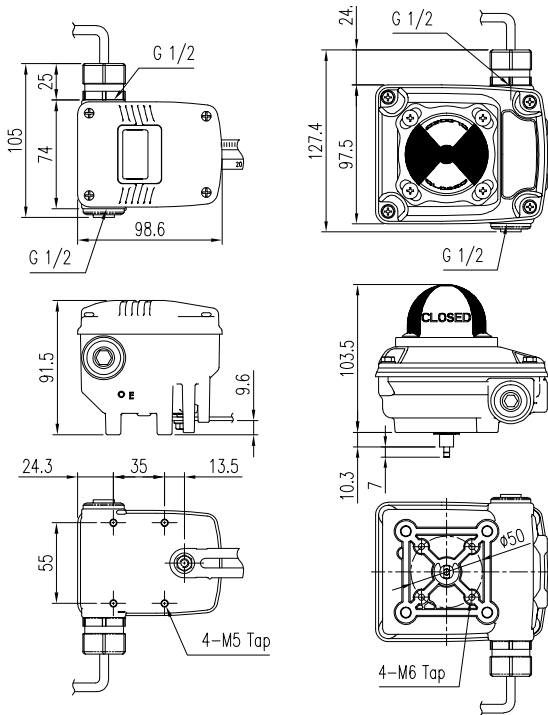

Fig. 2-15: Linear Remote Sensor

Fig. 2-16: Rotary Remote Sensor

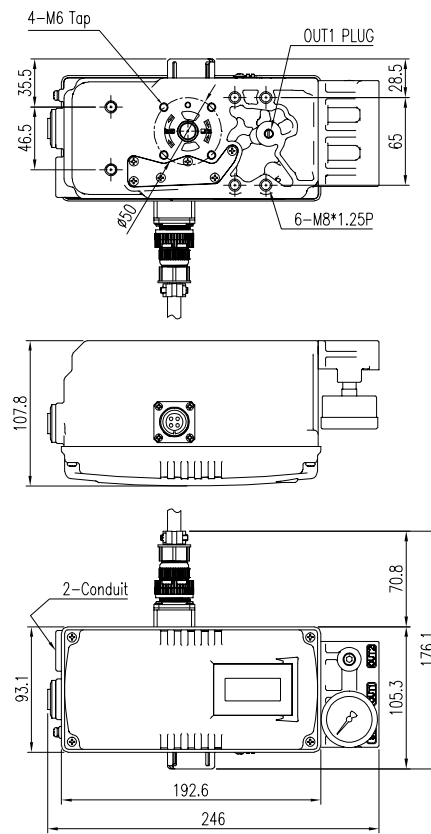

Fig. 2-17: YT-3301 Positioner

### 3 Installation

#### 3.1 Safety

When installing a positioner, please ensure to read and follow safety instructions.



- Any input or supply pressures to valve, actuator, and / or to other related devices must be turned off.
- Use bypass valve or other supportive equipment to avoid entire system “shut down”.
- Ensure there is no remaining pressure in the actuator.
- The positioner has a vent cover to exhaust internal air and drain internal condensation water. When installing the positioner, make sure the vent cover must be facing downward. Otherwise, the condensation water could cause damages to PCB.

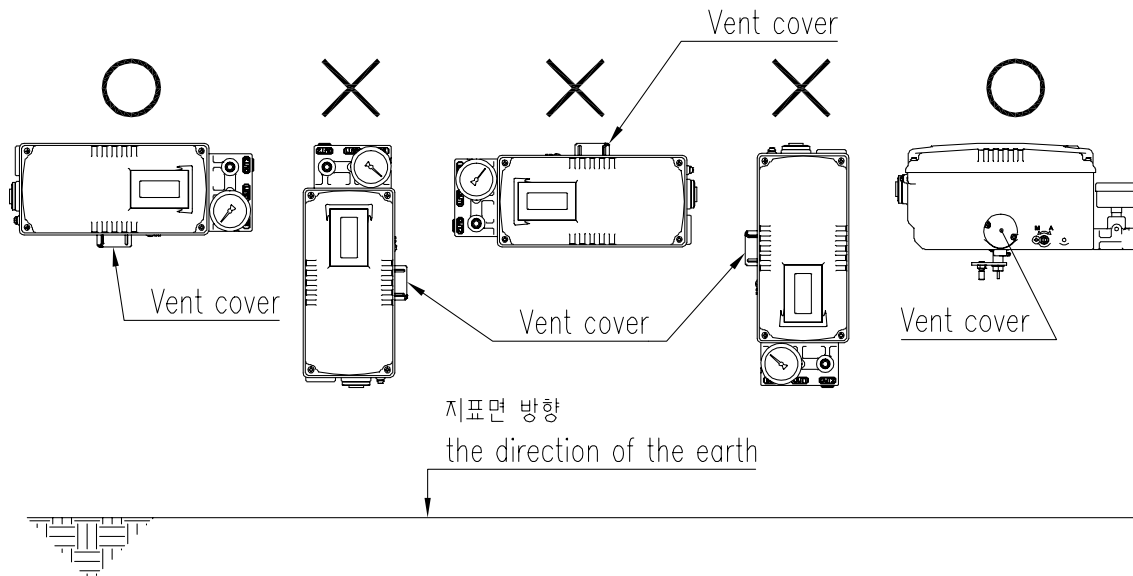

Fig. 3-1: The correct positions of a vent cover

- ※ Installed in accordance with the National Electrical Code(NEC), ANSI/NFPA 70, or CEC Part 1 as applicable.(FM approved product)

#### 3.2 Tools for installation

- Hex key set for hex socket cap bolts
- (+) & (-) Screw drivers
- Spanners for hexagonal-head bolts

### 3.3 Linear positioner Installation

Linear positioner should be installed on linear motion valves such as globe or gate type which uses spring return type diaphragm or piston actuators.

#### 3.3.1 Linear positioner Installation of Standard lever type

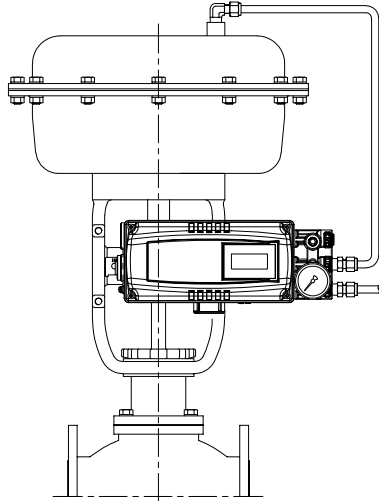

Fig. 3-2: YT-3300L / 3350L installation of standard lever type example

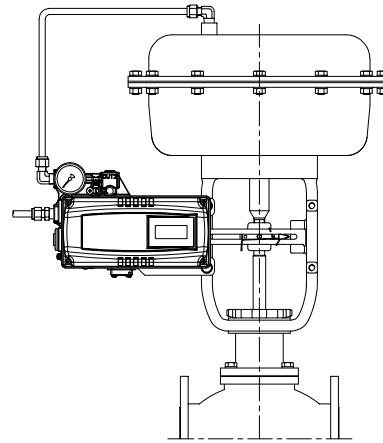

Fig. 3-3: YT-3303L installation example

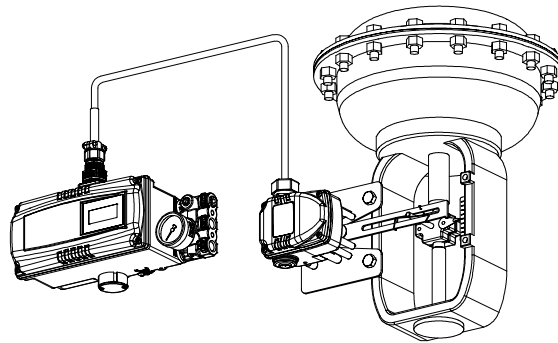

Fig. 3-4: YT-3301L installation example

Before proceeding with the installation, ensure following components are available.

- Positioner
- Linear remote sensor (Only YT-3301L)
- Remote cable (Only YT-3301L)
- Feedback lever and lever spring
- M6 nut and spring washer (fastening feedback lever to a main shaft)
- Bracket, bolts and washers for positioner or sensor – not supplied with the positioner
- Connection bar – not supplied with the positioner

### 3.3.1.1 Safety

Proper bracket must be made in order to adapt the positioner on the actuator yoke.  
Please consider following important points when a bracket is being designed.



- Positioner's feedback lever must be vertical to the valve stem at 50 % of the valve stroke.
- The connection bar of the actuator clamp for the feedback lever should be installed in such a way that the valve stroke length coincides with the corresponding figure in "mm" marked on the feedback lever. Improper setting may cause poor linearity

### 3.3.1.2 Standard lever type positioner Installation Steps

- 1) Assemble the positioner or remote sensor with the bracket made in previous step by fastening the bolts.

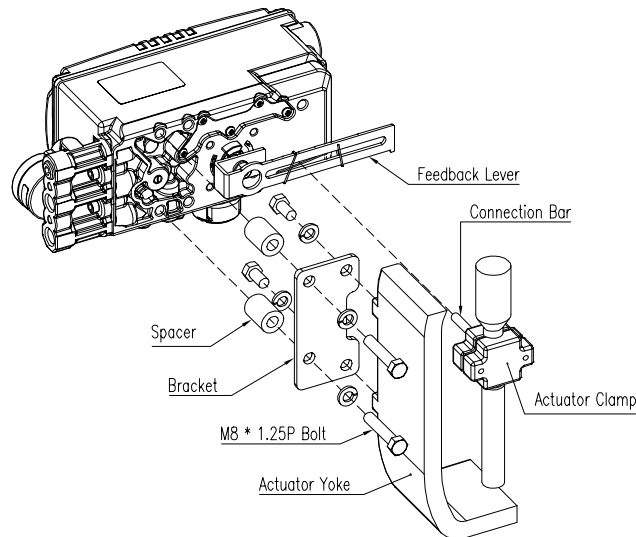

Fig. 3-5: YT-3300L / 3350L (Standard Lever Type)

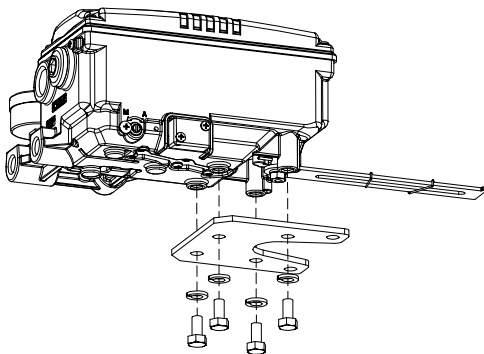

Fig. 3-6: Attaching positioner to bracket (YT-3303L)

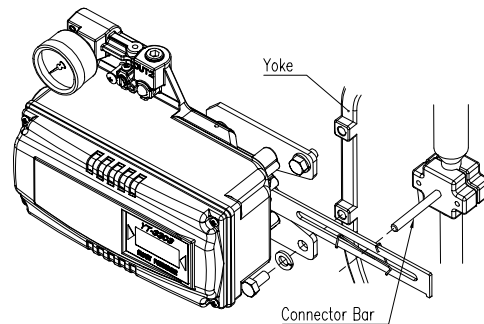

Fig. 3-7: Attaching the bracket to actuator yoke (YT-3303L / 3301L)

- 2) Attach the positioner (or remote sensor) with the bracket to the actuator yoke  
– **DO NOT TIGHTEN THE BRACKET COMPLETELY.**

- 3) Connect connection bar to the actuator clamp. The hole gap on the feedback lever is 6.5 mm so the connection bar's outer diameter should be less than 6 mm.
- 4) Connect an air-filter regulator to the actuator temporarily. Supply enough air pressure to the actuator in order to position the valve stroke at 50 % of the total stroke.

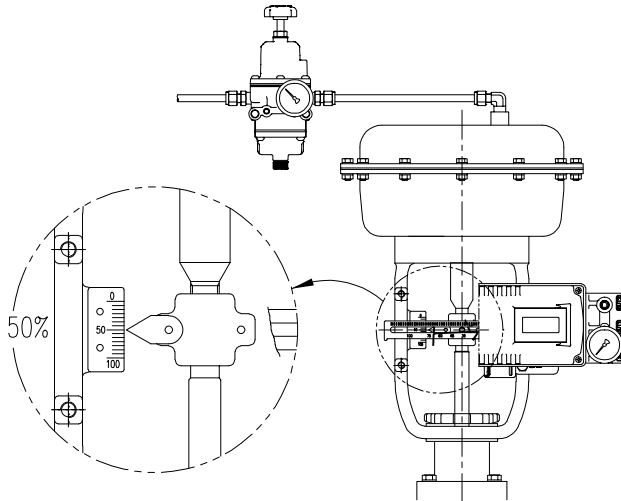

Fig. 3-8: YT-3300L / 3350L (Standard Lever Type)

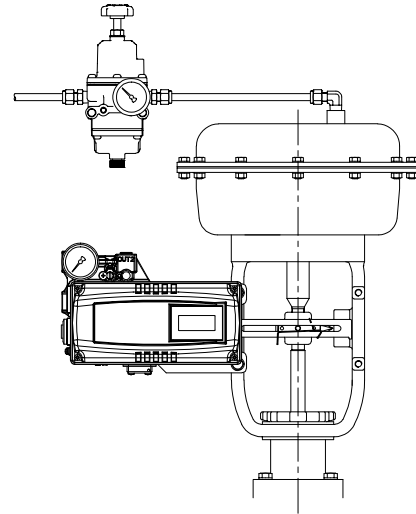

Fig. 3-9: YT-3303L / 3301L

- 5) Insert the connection bar between the feedback lever and lever spring. The connection bar must be located upward from the lever spring as shown below left figure. If it is located downward from the lever spring as shown below right figure, the connection bar or the lever spring will be worn out quickly because of excessive strong tension.

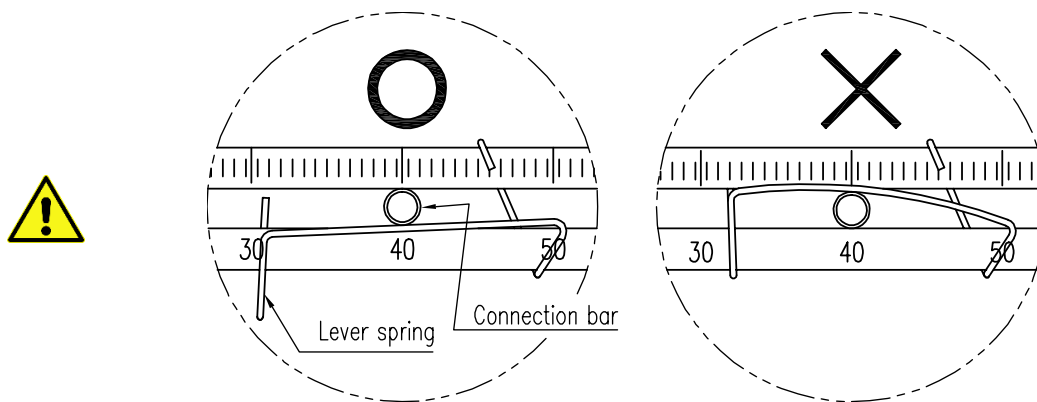

Fig. 3-10: Proper way to insert connection bar between feedback lever and lever spring

- 6) Check if feedback lever is vertical to the valve stem at 50 % of the valve stroke. If it is not vertical, adjust the bracket or the connection bar to make vertical. Improper installation may cause poor linearity.

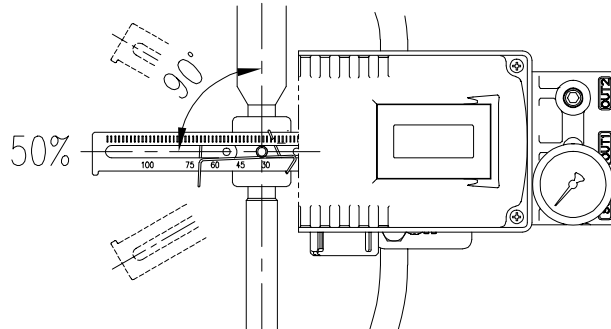

Fig. 3-11: YT-3300L / 3350L Feedback lever and valve stem

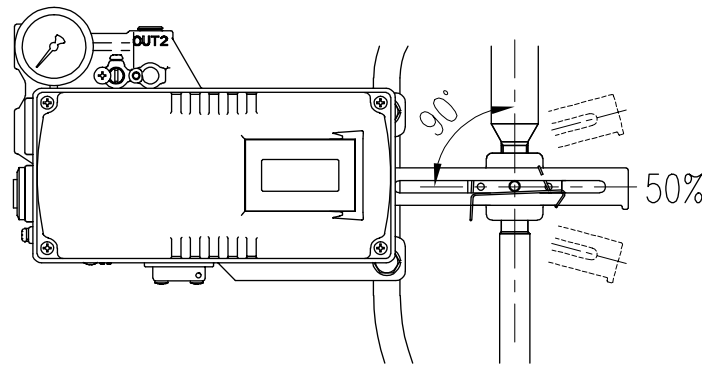
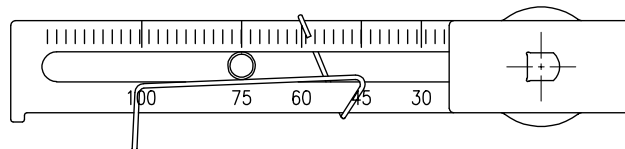

Fig. 3-12: YT-3303L / 3301L Feedback lever and valve stem

- 7) Check the valve stroke. The stroke numbers are engraved on the feedback lever of the positioner. Position the connection bar at the number on the feedback lever which corresponds with the desired valve stroke. To adjust, move the bracket, the connection bar or both.

※ The effective linear lever angle of YT-3300L / 3350L is 60 degree and it of YT-3303L / 3301L is 30 degree.

Stroke : 75 mm



Stroke : 45 mm

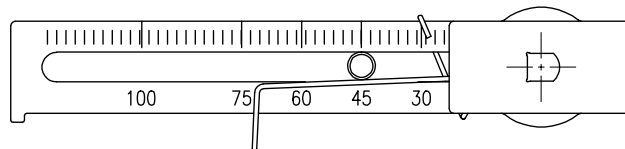

Fig. 3-13: YT-3300L / 3350L Feedback lever and location of the connection bar

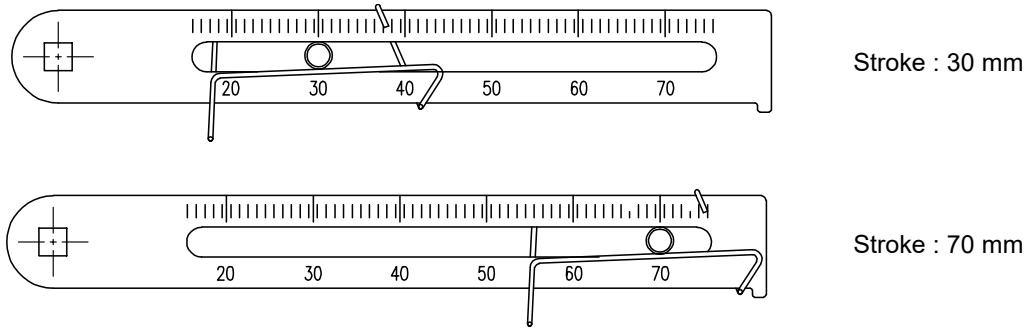

Fig. 3-14: YT-3303L / 3301L Feedback lever and location of the connection bar



- 8) After installing the positioner, operate the valve from 0 % to 100 % stroke by using direct air to the actuator. On both 0 % and 100 %, the feedback lever should not touch the lever stopper, which is located on the backside of the positioner. If the feedback lever touches the stopper, the positioner should be installed further away from center of the actuator.

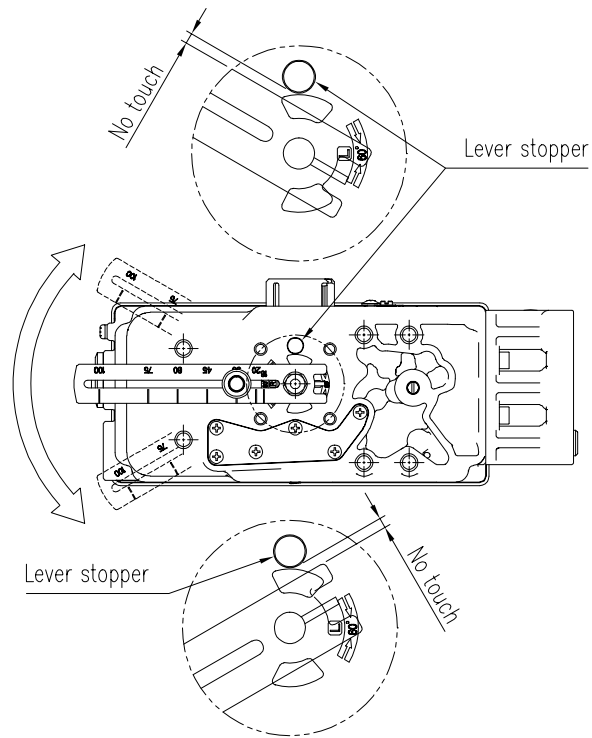

Fig. 3-15: YT-3300L / 3350L Feedback lever should not touch lever stopper on 0 % ~ 100 % valve stroke.

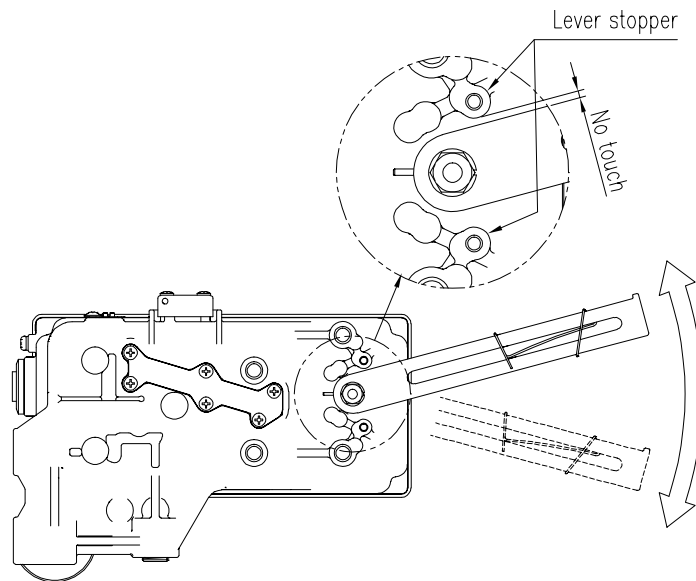

Fig. 3-16: YT-3303L / 3301L Feedback lever should not touch lever stopper on 0 % ~ 100 % valve stroke.

- 9) After the installation, tighten all of the bolts on the bracket and the connection bar.

### 3.3.2 YT-3300L / 3350L Installation of Adapter lever type (on tubeless actuator)

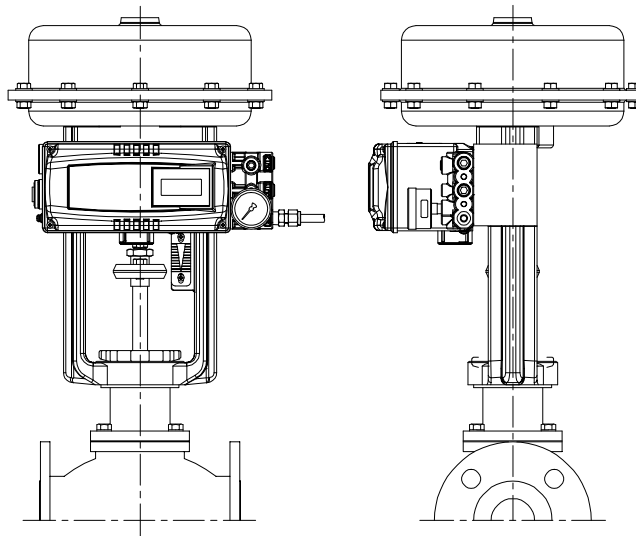

Fig. 3-17: YT-3300L / 3350L installation of adapter lever type example

Before proceeding with the installation, ensure following components are available.

- Positioner
  - Feedback lever
  - M6 nut and spring washer (fastening feedback lever to a main shaft of positioner)
  - O-ring(Connect out1 port of positioner and actuator) – not supplied with the unit
  - 1/4 plug – not supplied with the unit
  - Adapter holder – not supplied with the unit
  - 2 pcs x bolts (M8 x 1.25P) – not supplied with the unit
- ⊗ When using adapter lever, generally tubeless actuator which doesn't requires pipe between actuator and positioner is used. Therefore, in this section, installation method of tubeless actuator and positioner will be introduced like below.

#### 3.3.2.1 Safety



- Positioner's feedback lever must be vertical to the valve stem at 50 % of the valve stroke.
- Adapter of feedback lever should be installed in such a way that the valve stroke length coincides with the corresponding figure in "mm" marked on the feedback lever.

3.3.2.2 Adapter lever type positioner Installation Steps

- 1) Remove Out1 Plug(Fig. 3-19) on the bottom of the positioner. Plug up out1 port of gauge block with 1/4 plug using sealant.
- 2) Check the valve stroke. The stroke numbers are engraved on the feedback lever of the positioner. Position the adapter at the number on the feedback lever which corresponds with the desired valve stroke. To adjust, loosen M6 nut behind the adapter, move the adapter to correct position, and then tighten the M6 nut.

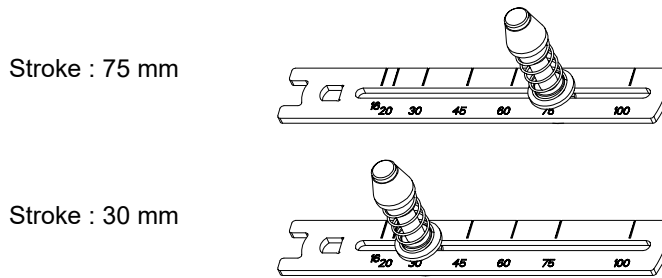

Fig. 3-18: Feedback lever and location of the connection bar

- 3) **Loosen Adapter holder on actuator's stem.**
- 4) Add O-ring between the positioner and actuator and attach the positioner to the actuator yoke tightly by fastening the bolts (M8 x 1.25P, 2 pieces).

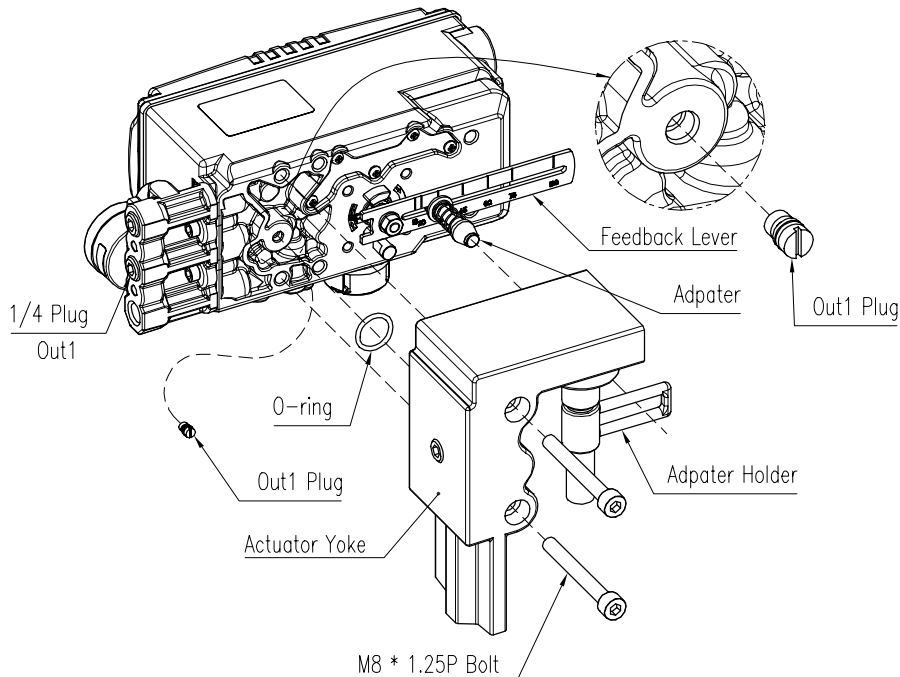

Fig. 3-19: Installing the positioner on the actuator

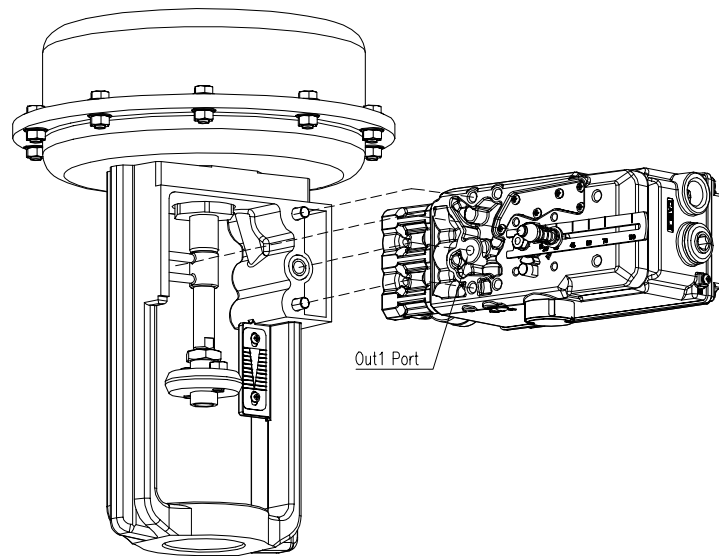

Fig. 3-20: YT-3300 / 3350L(Adapter Lever Type)

- 5) Connect Air-filter regulator to Supply port of the positioner.
- 6) Turn the Auto/Manual switch counterclockwise (toward “M”). Refer to 6.2 for more detail. Supply enough air pressure to the actuator in order to position the valve stroke at 50 % of the total stroke.
- 7) Check if feedback lever is vertical to the valve stem at 50 % of the valve stroke. If it is not vertical, adjust the adapter holder on the actuator’s stem to make vertical – **DO NOT TIGHTEN THE ADAPTER HOLDER COMPLETELY.** Improper installation may cause poor linearity. Refer to Fig 3-11.
- 8) After installing the positioner, operate the valve from 0 % to 100 % stroke by using direct air to the actuator. On both 0 % and 100 %, the feedback lever should not touch the lever stopper, which is located on the backside of the positioner. If the feedback lever touches the stopper, the adapter holder should be moved or the adapter of feedback lever should be moved further away from the main shaft of the positioner. Refer to Fig 3-15.
- 9) After the installation, tighten the adapter holder. And Turn the Auto/Manual switch clockwise (toward “A”) tightly. Refer to 6.2 for more detail.



### 3.4 Rotary positioner Installation

Rotary positioner should be installed on rotary motion valve such as ball or butterfly type which uses rack and pinion, scotch yoke or other type of actuators which its stem rotates 90 degrees. Before proceeding with the installation, ensure following components are available.

#### 3.4.1 YT-3300R / 3350R Components

- Positioner
- Fork lever (Only Fork lever type)
- Rotary bracket set (2 pieces) → The upper brackets of fork lever type and Namur type are different.
- 4 pcs x hexagonal headed bolts (M8 x 1.25P) → Fork lever type
- 4 pcs x M8 plate washers → Fork lever type
- 4 pcs x wrench headed bolts (M6 x 1P x 10L) → Namur type, For the positioner and the upper bracket
- 4 pcs x wrench headed bolts (M6 x 1P x 15L) : For the bracket set
- 4 pcs x M6 nuts : For the bracket set
- 4 pcs x M6 spring washers : For the bracket set
- Bolts and washers to attach bracket to actuator – not supplied with the positioner

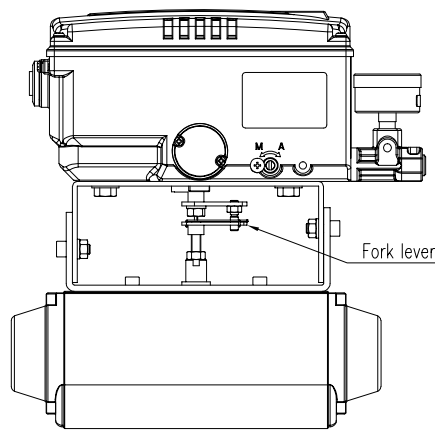

Fig. 3-21: YT-3300R / 3350R Fork lever type

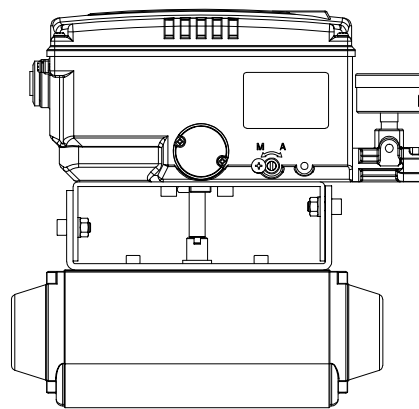

Fig. 3-22: YT-3300R / 3350R Namur type

### 3.4.2 YT-3303R Components

- Positioner
- Fork lever (Only Fork lever type)
- Rotary bracket set (2 piece)
- 4 pcs x hexagonal headed bolts (M8 x 1.25P)
- 4 pcs x M8 plate washers
- 4 pcs x wrench headed bolts (M6 x 1P x 15L)
- 4 pcs x M6 nuts
- 4 pcs x M6 spring washers
- Bolts and washers to attach bracket to actuator – not supplied with the positioner

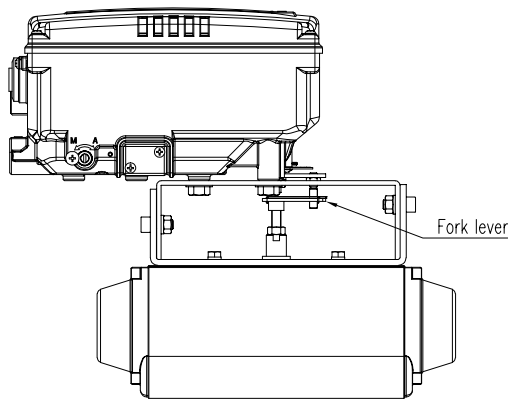

Fig. 3-23: YT-3303R Fork lever type

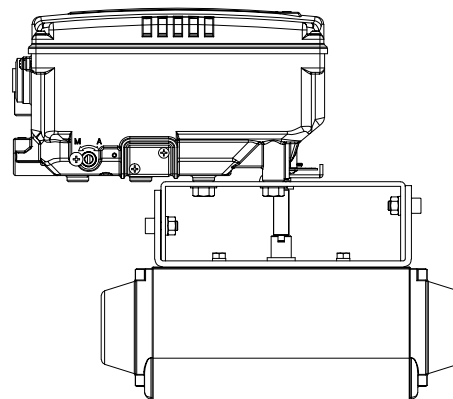

Fig. 3-24: YT-3303R Namur type

### 3.4.3 YT-3301R remote sensor components

- Rotary remote sensor
- Bracket for actuator stem height 20mm (1 piece)
- 4 pcs x hexagonal headed bolts (M6)
- 4 pcs x M6 spring washers
- Bolts and washers to attach bracket to actuator – not supplied with the positioner

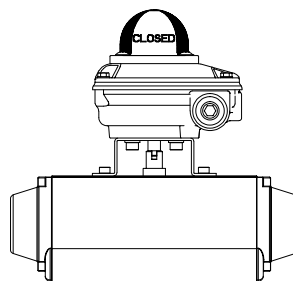

Fig. 3-25: YT-3301R Rotary remote sensor

3.4.4 Rotary Bracket Information (Only YT-3300R / 3350R / 3303R)



The rotary bracket set (included with the positioner) contains two components. (but the upper brackets of Fork lever type and Namur type are different in case of YT-3300 / 3350). The bracket is designed to fit onto the actuator with 20 mm, 30 mm and 50 mm stem height (H) according to VDI/VDE 3845 standard. Please refer to below table how to adjust the height of the bracket.

Actuator stem height (H)	Markings of bolt holes			
	A-L	B-L	A-R	B-R
20 mm	H : 20	H : 20, 30	H : 20	H : 20, 30
30 mm	H : 30	H : 20, 30	H : 30	H : 20, 30
50 mm	H : 50	H : 50	H : 50	H : 50

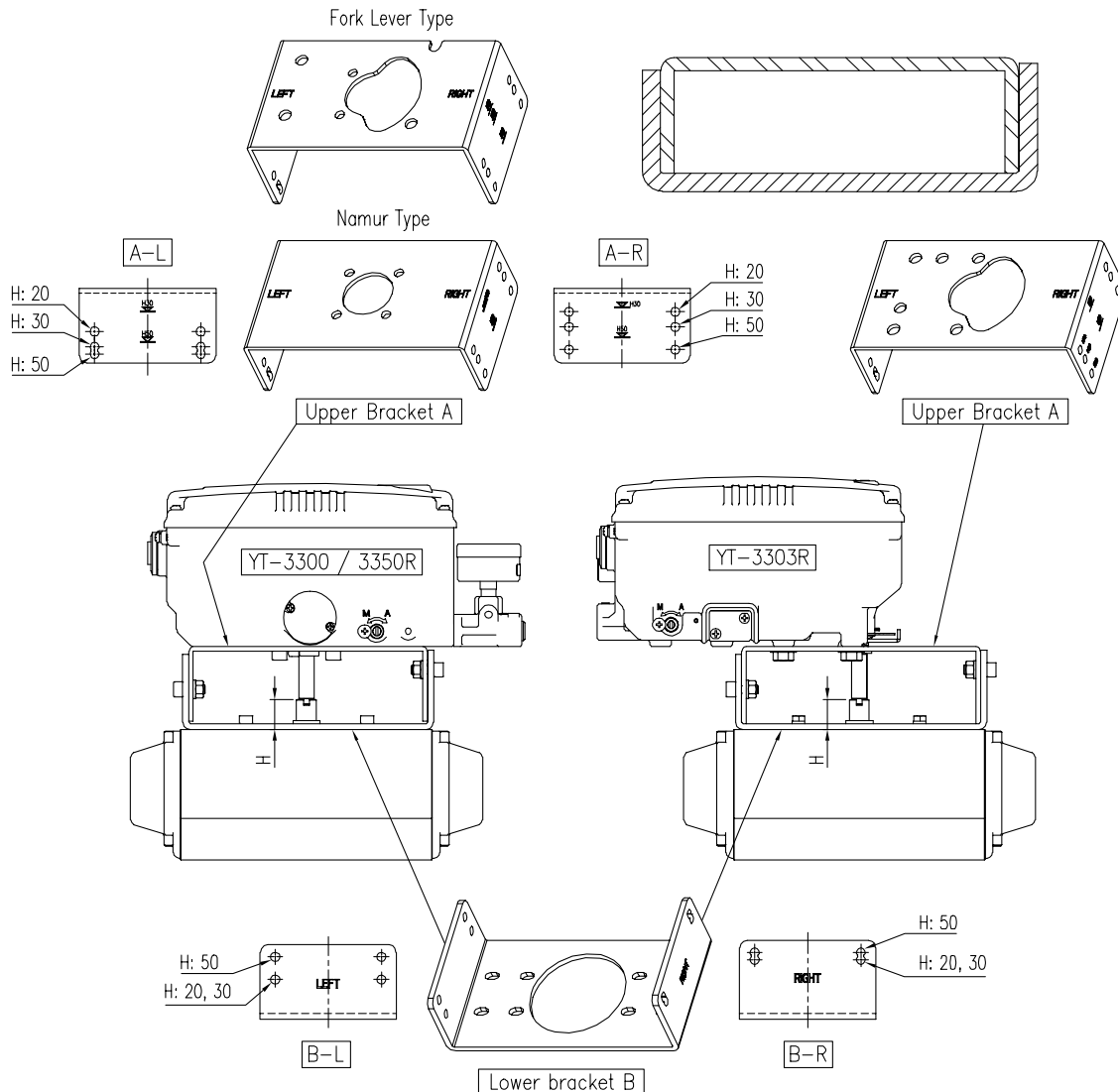

Fig. 3-26: YT-3300R / 3350R / 3303R Brackets and positioner

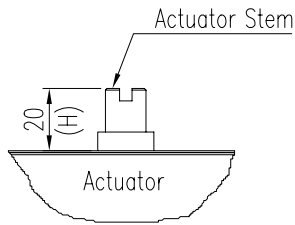

Fig. 3-27: Actuator stem Height

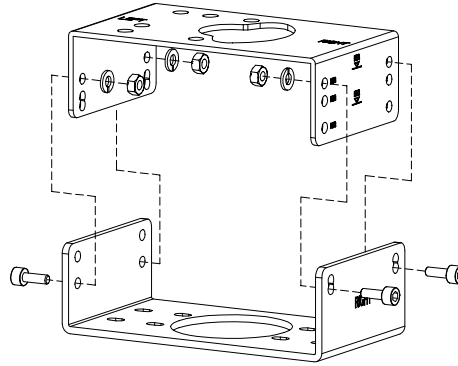

Fig. 3-28: Exploded Brackets

### 3.4.5 Rotary positioner Installation Steps

- 1) Please check the actuator's stem height and adjust the brackets by referring to the above bracket table.
- 2) Attached the brackets onto the actuator. It is recommended to use spring washer so the bolts will not be loosen from vibration.
- 3) Set rotation position of the actuator stem at 0 %. For single acting actuator, it is easy to check 0 % point by supplying no pressure to the actuator. For double acting actuator, check actuator stem's rotation direction – clockwise or counter-clockwise - by supplying pressure to the actuator.
- 4) (Only Fork lever type) Install the fork lever after setting actuator's stem at 0 %. Check the actuator stem's rotation direction – clockwise or counter-clockwise. Installation angle of the fork lever should be 45° to the longitudinal direction of the actuator.

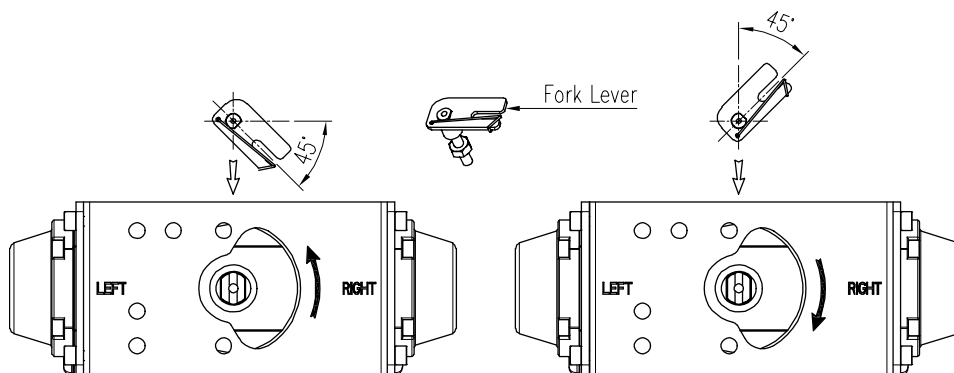

Fig. 3-29: Counter-clockwise and clockwise rotation.



- 5) (Only Fork lever type) After setting fork lever position, fasten lock nuts which are located on the bottom of the fork lever. Ensure to set the gap between the top of upper bracket and the top of the fork lever within **23 ~ 28 mm**(YT-3300R / 3350R) and **6 ~ 11 mm**(YT-3303R).

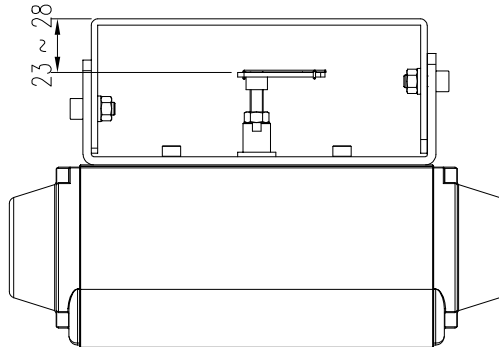

Fig. 3-30: Height to the bracket (fork lever type of YT-3300R / 3350R)



- 6) Attach the positioner to the bracket. <Only fork lever type of YT-3300R / 3350R / 3303R: Fix the clamping pin (5 mm Dia.) into the fork lever slot and insert center pin (2mm Dia.) of the main shaft of the positioner into the hole of center of the fork lever. The clamping pin will be locked to the fork lever spring.> Setting alignment of center of main shaft of the positioner and center of the actuator's stem is very important. Poor alignment of the main shaft and the actuator's stem decreases the positioner's durability due to unnecessary forces on the main shaft.

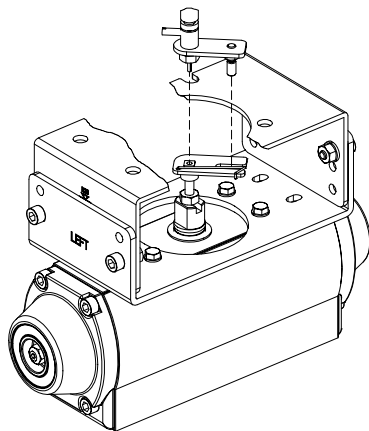

Fig. 3-31: Main shaft center alignment (Fork lever)

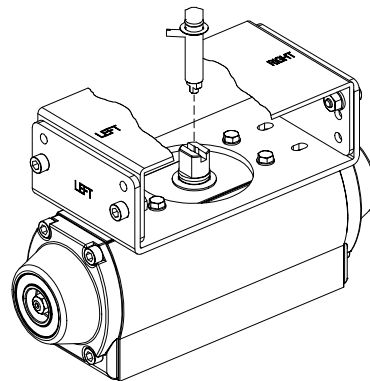

Fig. 3-32: Main shaft center alignment (Namur)

- 7) (Only YT-3300 / 3350) After installing the positioner, operate the valve from 0 % to 100 % stroke by using direct air to the actuator. On both 0 % and 100 %, the indicator should not touch the indicator stopper, which is located on the backside of the positioner. If the indicator touches the indicator stopper, recheck the installation position and angle of the positioner.

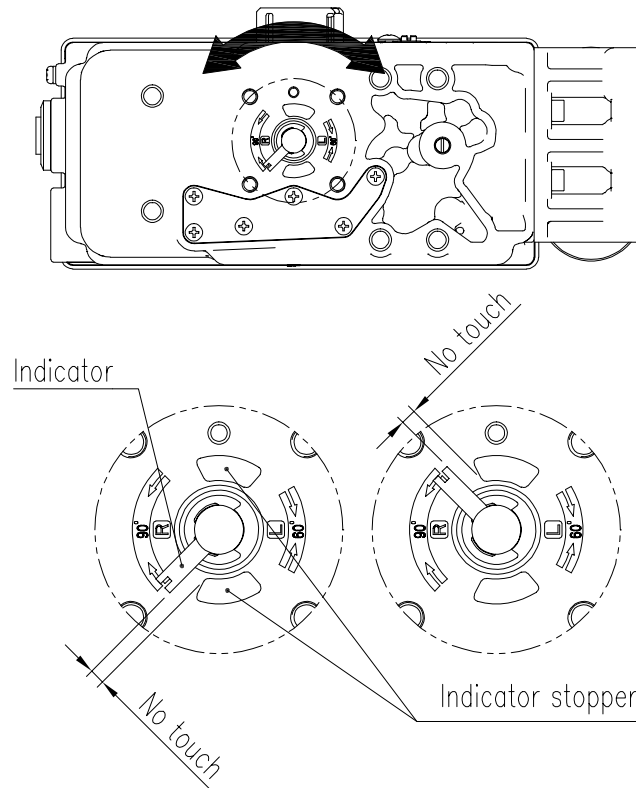

Fig. 3-23: Indicator should not touch indicator stopper on 0 % ~ 100 % valve stroke.

- 8) Tighten the positioner and the bracket with bolts **after checking the positioner's position.**

## 4 Connection - Air

### 4.1 Safety

- Supply pressure should be clean and dry air – avoiding moisture, oil and dust.
- Always recommended to use air filter regulator (i.e. YT-200 series).
- Tapped Exhaust (AG option) is used when it is required to vent away the Group D gases to a safe area. Tapped Exhaust for use in FM & CSA Division approved hazardous locations must be sealed to prevent leaks at the 1/4" NPT connection for use with Division Group D gases such as natural gas or methane as the process medium.

### 4.2 Supply Pressure Condition



- Dry air with dew point of at least 10 °C lower than ambient temperature.
- Avoid from dusty air. Use 5 micron or smaller filter.
- Avoid oil.
- Comply with ISO 8573-1 or ISA 7.0.01.
- Supply pressure range is 0.14 ~ 0.7 MPa (1.4 ~ 7 bar)
- Set air filter regulator's pressure level 10 % higher than actuator's spring range pressure.

### 4.3 Piping Condition



- Ensure inside of pipe is clean of obstructions.
- Do not use pipeline that is squeezed or shows any type of damages.
- Pipeline should have more than 6mm of inner diameter (10 mm outer diameter) to maintain flow rate.
- The length of pipeline system should not be extremely long. Longer pipeline system may affect flow rate due to the friction inside of the pipeline.

4.4 Connection – Piping with actuator

4.4.1 Single acting actuator

Single acting type positioner is set to use only OUT1 port. OUT1 port of positioner should be connected with supply port of actuator when using spring return actuator of single acting type.

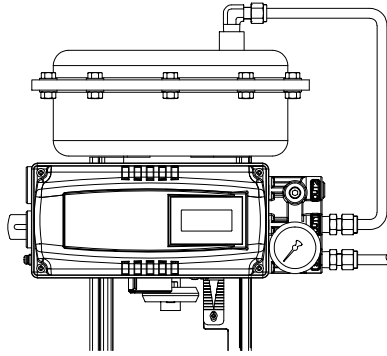

Fig. 4-1: Single acting linear actuator  
(YT-3300L / 3350L / 3303L)

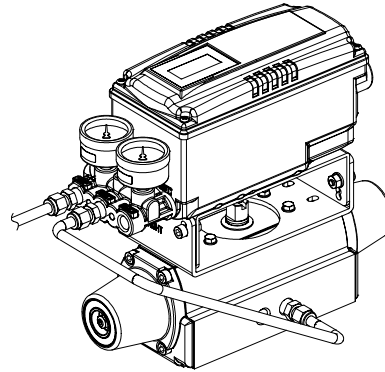

Fig. 4-2: Single acting rotary actuator  
(YT-3300R / 3350R / 3303R)

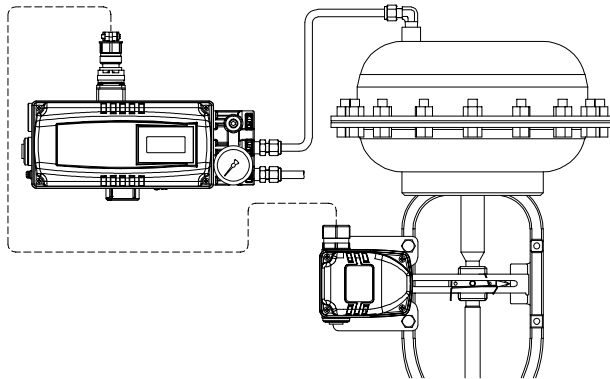

Fig. 4-3: Single acting linear actuator (YT-3301L)

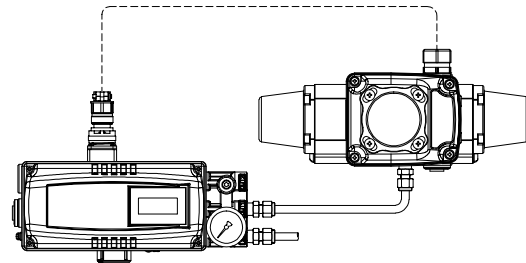

Fig. 4-4: Single acting rotary actuator (YT-3301R)

#### 4.4.2 Double acting actuator

Double acting type positioner is set to use OUT1 and OUT2 port. As input signal increases, the supply pressure will be supplied through OUT1 port.

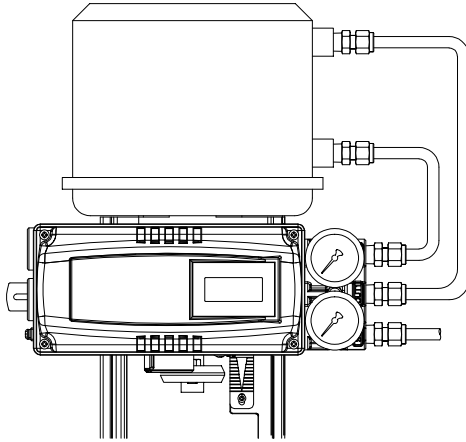

Fig. 4-5: Double acting linear actuator  
(YT-3300L / 3350L / 3303L)

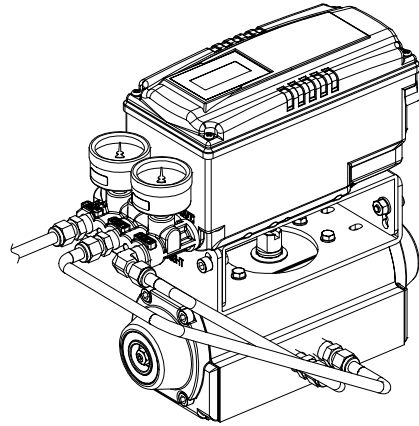

Fig. 4-6: Double acting rotary actuator  
(YT-3300R / 3350R / 3303R)

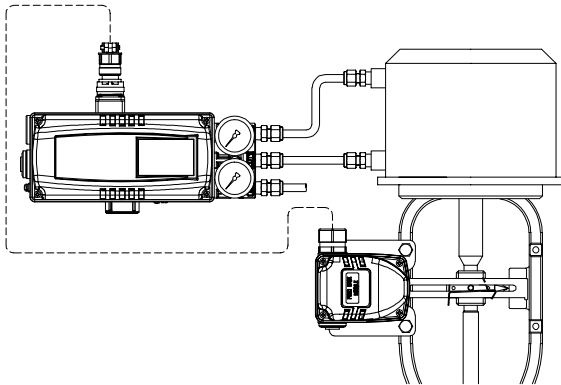

Fig. 4-7: Double acting linear actuator (YT-3301L)

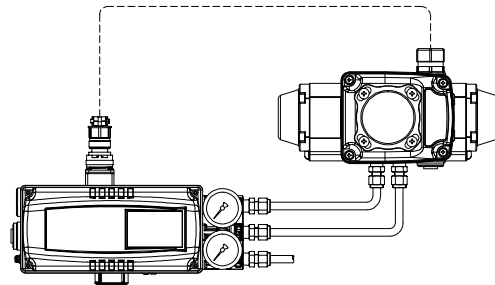

Fig. 4-8: Double acting rotary actuator (YT-3301R)

## 5 Connection – Power

### 5.1 Safety



- There are two conduit entries on the product. See “2.4 Product Code” for conduit entry threads.
- Before connecting terminal, ensure that the power is off completely.
- Please use ring terminal to protect against vibration or any other external impact.
- Positioner usually uses 4 ~ 20 mA DC. Minimum ampere of input signal of standard type positioner is 3.6 mA (NCS type) or 3.2 mA (Potentiometer type), PTM internal type is 3.7 mA (NCS type) or 3.6 mA (Potentiometer type) and HART or HART+PTM internal type is 3.8 mA but maximum ampere of input signal should be 24 mA or under.
- Compliance voltage of current source must be Min. 10 V and Max. 28 V. If the length of the supply cable between the current source and the positioner is long, or if there is a filter or safety barrier, then consider using a current source which could supply higher Compliance voltage.
- Positioner with PTM options must be supplied with **9 ~ 28 V DC** separately. For mechanical limit switch option, separate **12 ~ 30 V DC** must be supplied. For inductive proximity limit switch option, separate **8.2 V DC** must be supplied.
- **DO NOT connect Voltage source (9 ~ 28 V DC) to Input (4 ~ 20 mA DC) terminal (IN+, IN-) as it will cause PCB failure.**
- Positioner should be grounded.
- Please use twisted cable with conductor section are 1.25 mm<sup>2</sup> and that is suitable for 600 V (complying with the conductor table of NEC Article 310). The outer diameter of the cable should be between 6.35 ~ 10 mm. Use shield wire to protect against electro-magnetic field and noise.
- Please do not install the cable near high noise equipment, such as high-capacity transformer or motor.
- Please ensure that keep away magnetic materials from a product. It may cause malfunction. For a magnetic screwdriver, It must be away more than 30 cm from the positioner.

5.2 Connection

5.2.1 Standard Terminals

Terminal name	Signal name	Function
IN+	Current input signal (+)	Apply analog current command 4 ~ 20 mA to this terminal to supply power and signal to the positioner.
IN-	Current input signal (-)	
F.G	Safety ground	Safety ground
OUT+	Analog output signal (+)	Analog feedback signal indicating the position of the current valve
OUT-	Analog output signal (-)	

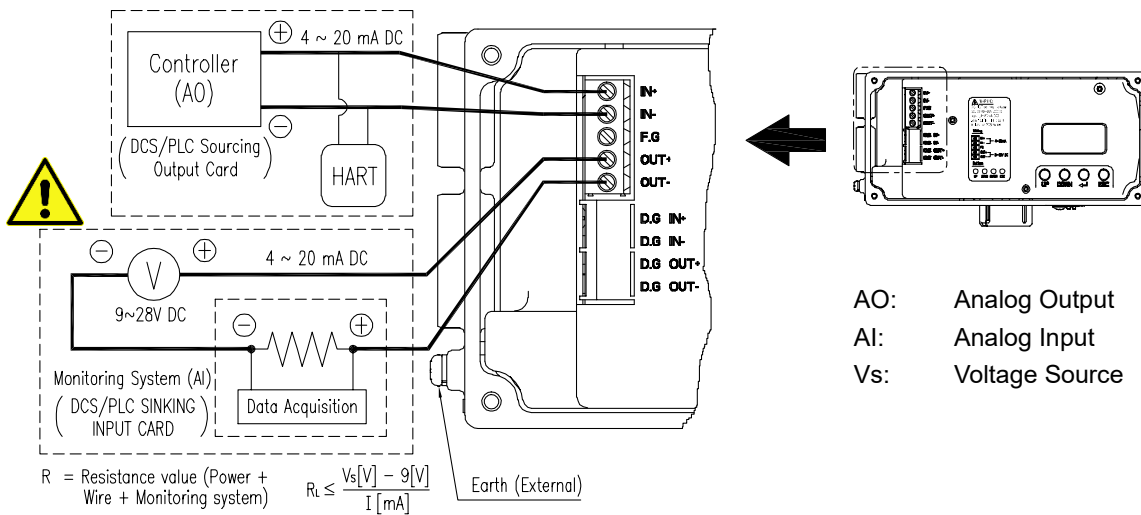

Fig. 5-1: Terminal Overview

5.2.2 Terminals with micro-limit switch option

The input and output terminals of products equipped with micro-limit switches can be connected to an external system as shown below. Refer to the table below for the signal name and function of each terminal.

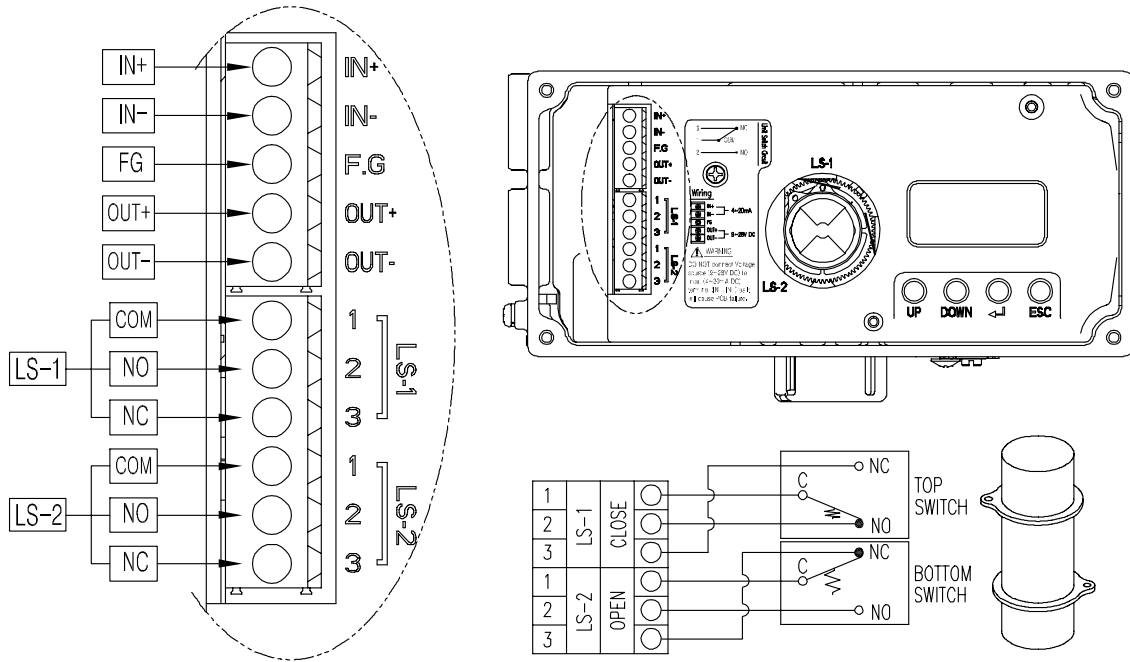

Fig. 5-2: Mechanical Switch Terminal

Terminal name	Signal name	Function
1, LS-1	Common terminal for Limit Switch 1	Common contact terminal for Limit Switch 1
2, LS-1	Normal open signal for Limit Switch 1	The contact of the Limit Switch 1 is closed when the valve passes through the preset position.
3, LS-1	Normal close signal for Limit Switch 1	The contact of the Limit Switch 1 opens when the valve passes through the preset position.
1, LS-2	Common terminal for Limit Switch 2	Common contact terminal for Limit Switch 2
2, LS-2	Normal open signal for Limit Switch 2	The contact of the Limit Switch 2 is closed when the valve passes through the preset position.
3, LS-2	Normal close signal for Limit Switch 2	The contact of the Limit Switch 2 opens when the valve passes through the preset position.

5.2.3 Terminals with inductive proximity Limit Switch option

The input and output terminals of products equipped with inductive proximity limit switch switches can be connected to an external system as shown below. Refer to the table below for the signal name and function of each terminal.

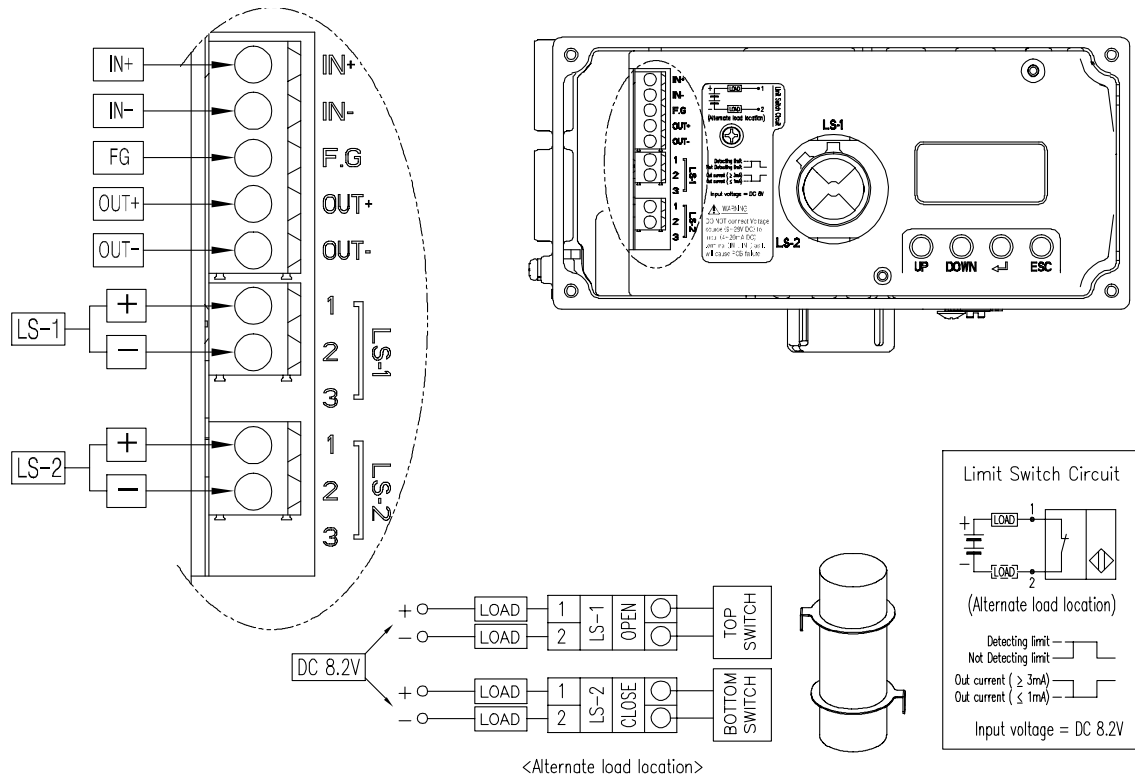

Fig. 5-3: Inductive proximity Sensor Switch Terminal

Terminal name	Signal name	Function
1, LS-1	Common terminal for Limit Switch 1	Common contact terminal for Limit Switch 1
2, LS-1	Normal open signal for Limit Switch 1	The contact of the Limit Switch 1 is closed when the valve passes through the preset position.
3, LS-1	No connection	Not used
1, LS-2	Common terminal for Limit Switch 2	Common contact terminal for Limit Switch 2
2, LS-2	Normal close signal for Limit Switch 2	The contact of the Limit Switch 1 opens when the valve passes through the preset position.
3, LS-2	No connection	Not used

# ایمن کنترل سهند

مرکز تخصصی طراحی، فروش و مشاوره

■ تجهیزات ابزار دقیق ■ تجهیزات ایمنی ■ تجهیزات ضد انفجار



Honeywell



آدرس: تهران - خیابان سمیه - بعد از تقاطع بهار - ساختمان ایرج - پلاک ۶۳ - واحد ۱۱

۰۹۳۹۵۱۸۸۱۶۴

۰۲۱-۸۸۳۴۱۴۸۳

۰۲۱-۸۶۰۷۲۸۲۳



IMEN  
CONTROL  
SAHAND

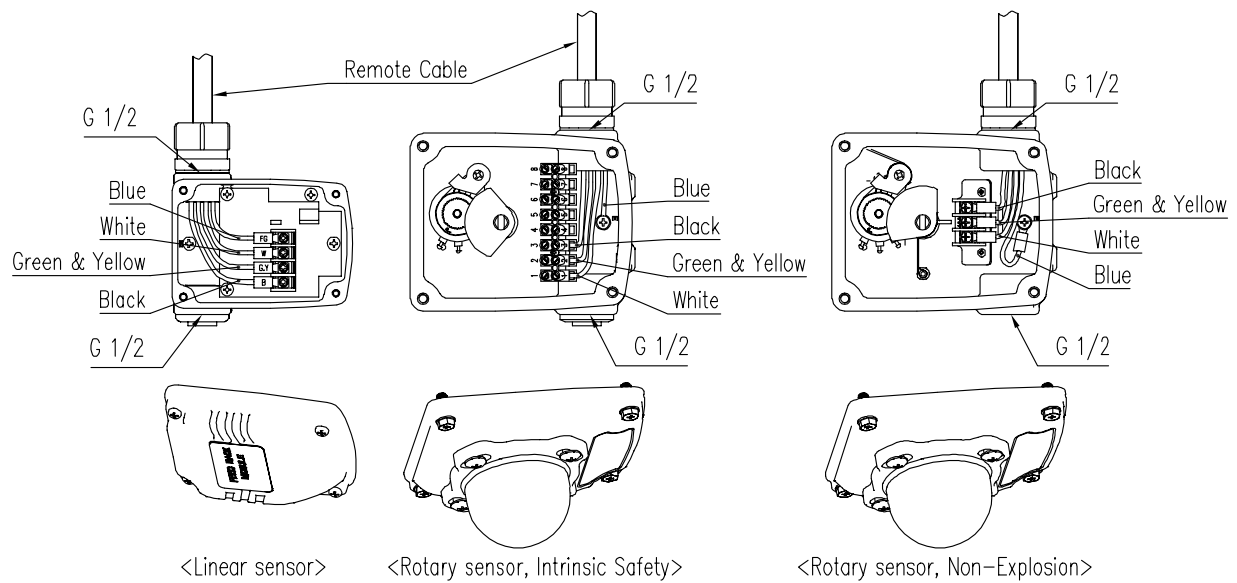

Fig. 5-4: Remote sensor and cables (Only YT-3301L)

### 5.3 Ground

- 1) Ground must be done before operating the positioner.
- 2) Open base cover and there is an internal ground "F.G" on the left hand.

An external ground bolt is located next to the conduit entry. Please make sure that the resistance is less than 100 ohm.

## 6 Adjustments

### 6.1 Limit Switch Adjustment

YT-3300 / 3350 can have limit switch option. If user wants to adjust the sensing position, please loosen bolts and adjust cam.

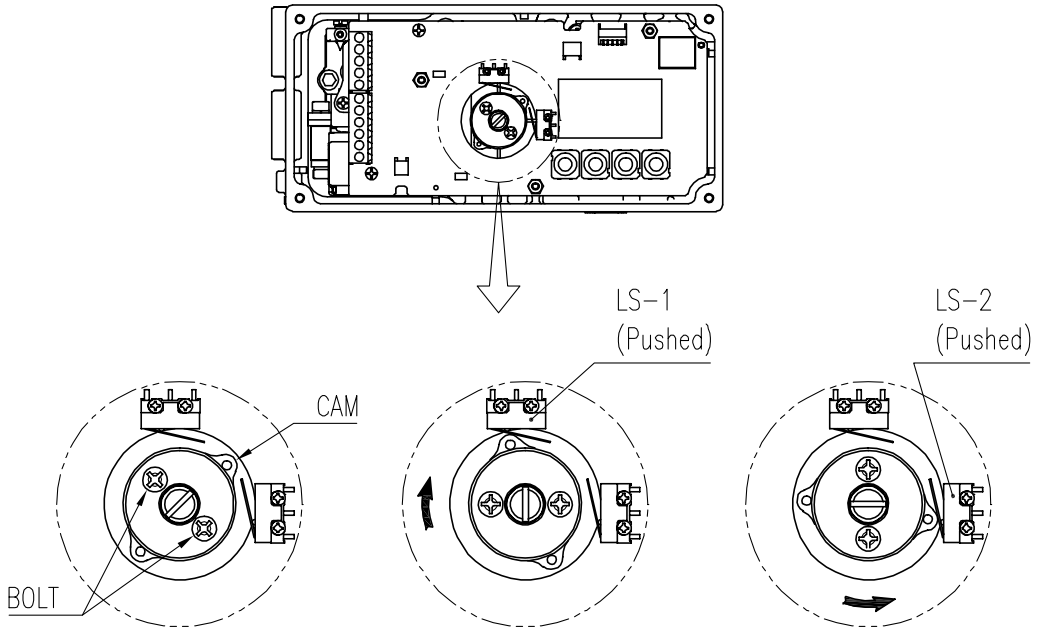

Fig. 6-1: Mechanical Type

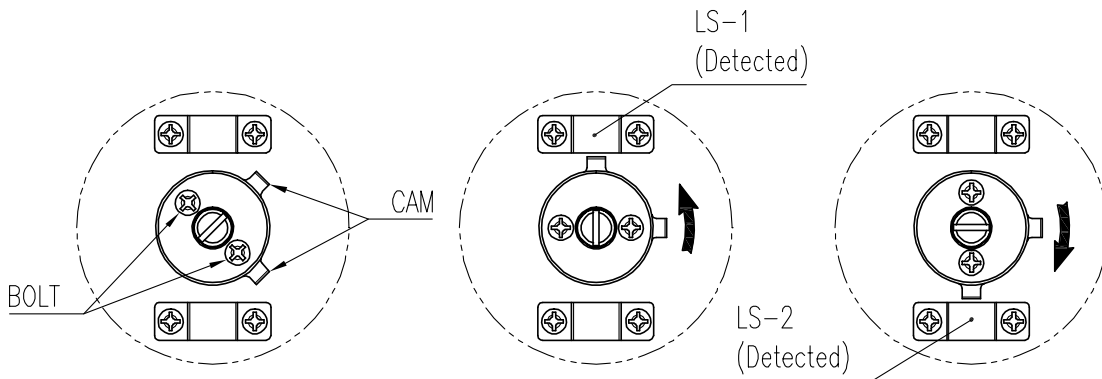

Fig. 6-2: Inductive proximity Type

## 6.2 A/M switch adjustment

- 1) On the right hand bottom of positioner, there is A/M switch (Auto/Manual). A/M Switch allows the positioner to be functioned as by-pass. If the switch is turned clockwise (toward “A”) and it is fasten tightly, then the supply pressure will be transferred to actuator through outport by positioner control. On the other hand, if the switch is turned counter-clockwise (toward “M”), it is loosened, then the supply pressure will be directly supplied to the actuator regardless of positioner control. It is extremely important to check the allowed pressure level of the actuator when the switch is loosened.
- 2) Check whether the supply pressure is too high.
- 3) After using “Manual” function, A/M switch should be returned to “Auto”.

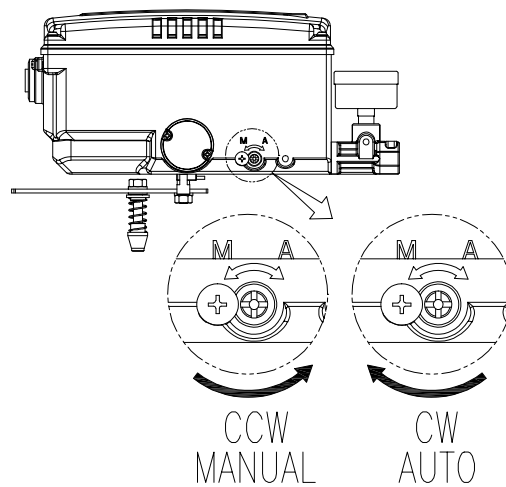

Fig. 6-3: A/M switch adjustment

### 6.3 Orifice Installment

Hunting can be occurred when the actuator's volume is too small. In order to prevent hunting, orifice can be used.

#### 6.3.1 Plate type Orifice Installment (except YT-3303)

By installing the plate type orifice, the flow rate of the supply pressure to actuator can be reduced. The diameter of orifice hole is 1 mm.

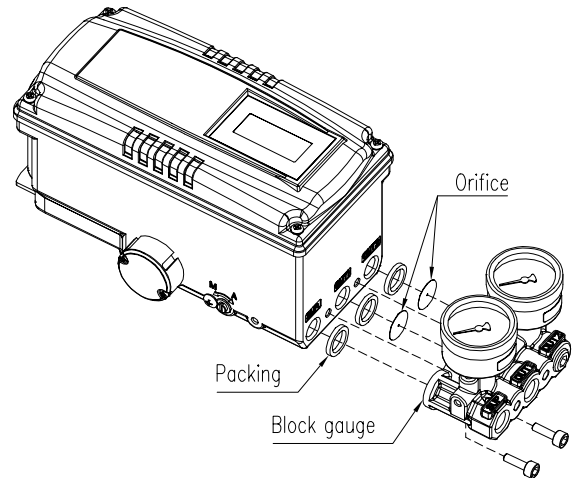

Fig. 6-4: Plate type Orifice installment

#### 6.3.2 Variable Orifice Adjustment (Only YT-3303)

By adjusting the orifice, the flow rate of the supply pressure to actuator can be adjusted. Please use (-) driver to adjust the orifice. When slot (-) of the orifice is vertical like the below left figure, the flow rate becomes maximum. When slot (-) of the orifice is horizontal like the below right figure, the flow rate becomes minimum.

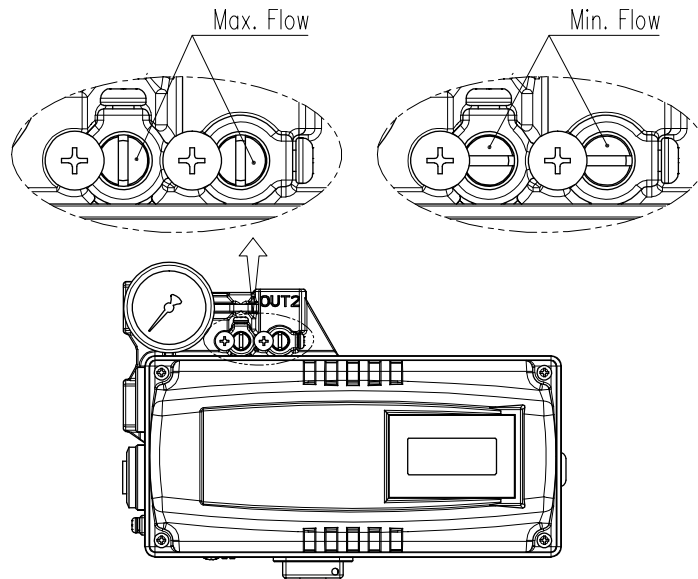

Fig. 6-5: Variable orifice adjustment

## 7 Optional Sub-PCB Installment

By adding sub-PCB, the positioner can have additional functions. There are 3 types of sub-PCB.

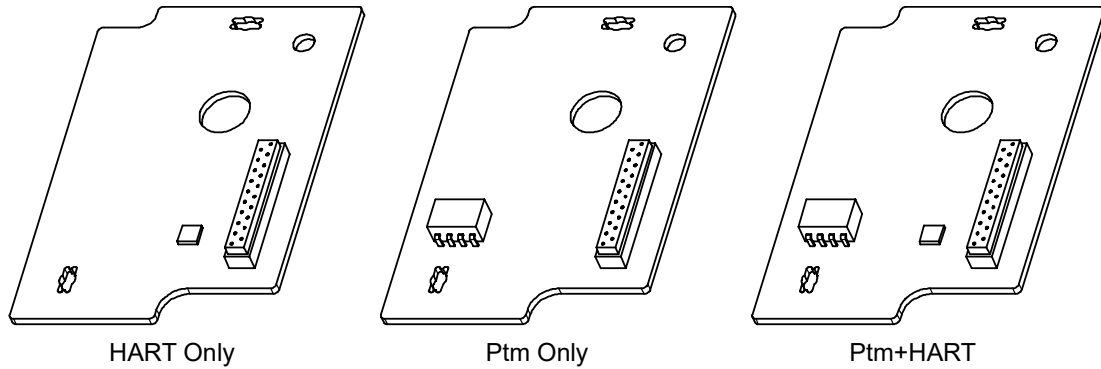

Fig. 7-1: Three types of Sub-PCB

When purchasing option sub-PCBs separately, 4 Bolts and 2 supports are supplied together with sub-PCB.

### 7.1 Installation steps

- 1) Mount 2ea of sub-PCB support on sub-PCB with 2ea of bolt.
- 2) Open base cover, PCB cover. Separate the Main PCB from base body.
- 3) Insert connector of sub-PCB into connector of main PCB correctly.
- 4) Fasten sub-PCB with the rest of bolt 2ea.

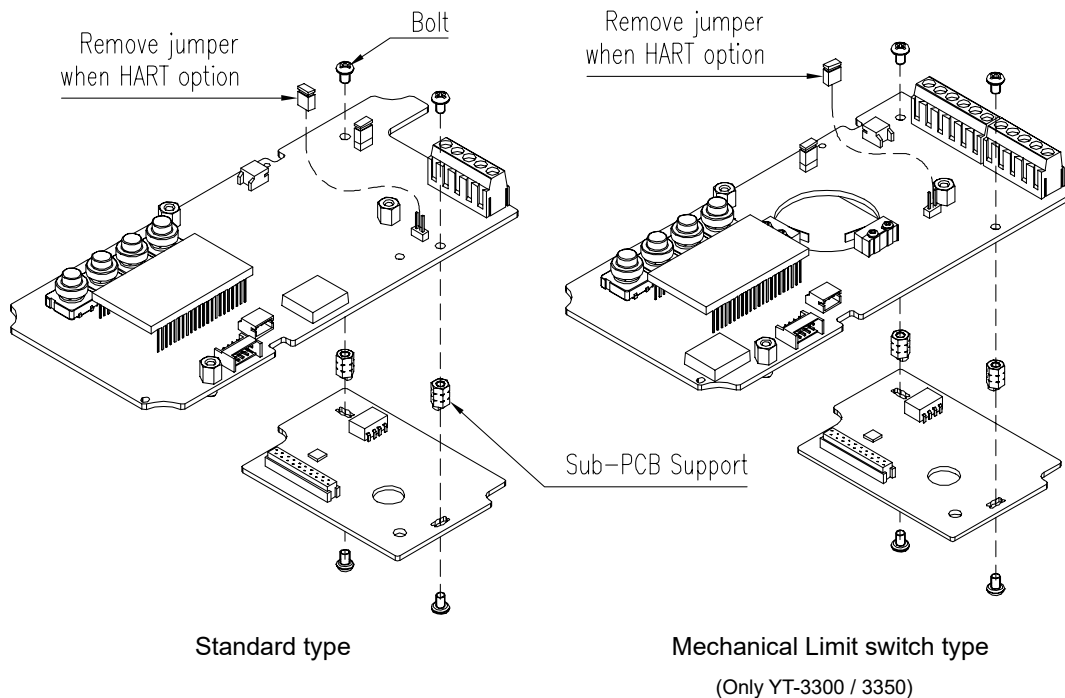
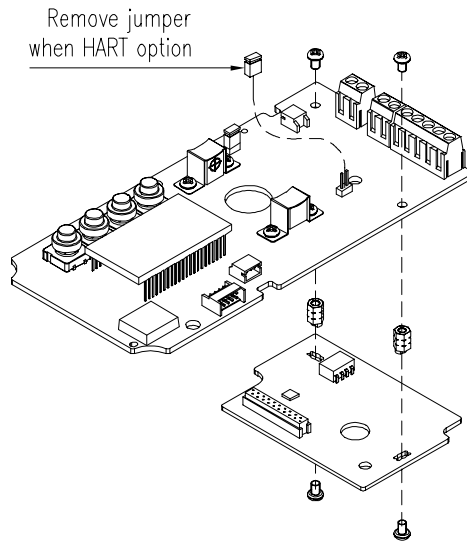

Fig. 7-2: Installation of Option PCB on Main PCBs



Inductive proximity limit switch type  
(Only YT-3300 / 3350)

Fig. 7-3: Installation of Option PCB on Main PCBs



**JP1 jumper must be removed, when HART option included sub-PCB is being mounted.**

- 5) After PTM sub-PCB is installed newly, values of PTM ZERO and PTM ENd must be calibrated for correct output signals. For the calibration of PTM ZERO and PTM ENd, please refer to section 9.10.2 of this manual.

## **8 Maintenance**

### **8.1 Supply air**

If Supply air pressure is not stable or Supply air is not clean, the positioner may not function properly. Air quality and pressure should be checked regularly to see if the air is clean and pressure set is normal.

### **8.2 Seals**

Once a year, it is recommend to check if there are any damaged parts of the positioner. If there are damaged rubber parts such as diaphragms, o-rings and packings, replace with new ones.

## 9 Auto Calibration and PCB Operation

### 9.1 Warning



Following process will operate valve and actuator. Before proceeding with any Auto Calibration, please separate valve from the entire system by using bypass valve, so Auto Calibration will not affect entire valve process.

### 9.2 LCD display and buttons

#### 9.2.1 LCD display and symbols

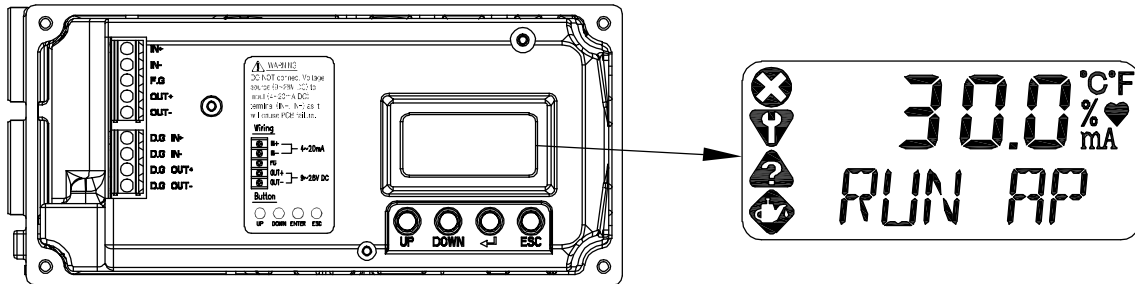

Fig 9-1

NE107 Symbols	Description	Symbols	Description
	Failure	°C	Degree in Celsius
	Functional Check	°F	Degree in Fahrenheit
	Out of Specifications	%	Percent
	Maintenance Required	♥	Communication status
		mA	Current in mA

The four symbols located on the left are the symbols that display alarm messages classified in four groups in accordance with NAMUR NE107. Assigning each alarm to a specific group of four groups can only be performed through EDD or DTM.

9.2.2 Button and function

Positioner has 4 buttons that perform various functions.

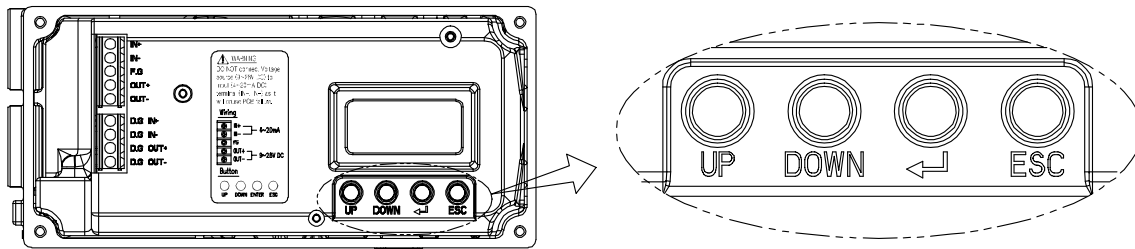

Fig 9-2

Buttons	Function
UP	Used to navigate to each menu at the same level or to increase the value of the selected parameter.
DOWN	Used to navigate to each menu at the same level in reverse order of UP button or to decrease the value of the selected parameter.
<←> (ENTER)	Use to select the current menu or function, or to store the value of a modified parameter.
ESC	Used go directly to parent menu from current menu.

9.3 Menu levels

The basic menu structure consists of the RUN Mode Monitor and the Configuration/Operation. The Run Mode Monitor menu allows you to monitor the values of various variables. The Configuration/Operation menu provides calibration and tuning, manual operation, configuration of I/O port function, configuration and self-test of positioner, configuration of diagnostic function, and basic information of the positioner. See below for information on how to move between Run Mode Monitor menu and Configuration/Operation menu and how to move within Run Mode Monitor menu or Configuration and Operation.



Press the <↵> button to select the lower menu of the Configuration/Operation menu. Press the ESC button to return to parent menu after completing configuration. Pressing the ESC button anywhere in the menu structure several times returns the user to the uppermost menu, Run Mode Monitor menu.

9.4 Run Mode (RUN)

The RUN Mode Monitor is displayed on the LCD display when power is provided to the positioner. Pressing the UP/DOWN button scrolls through the various process variables shown in table below. A "30.0 %" in the LCD display on the right indicates that the valve is in the 30 % position, and an "AP" indicates the abbreviation of "Actual Position".



The status variables displayed in the RUN Mode Monitor are divided into nine types as shown below.

On LCD	Name	Description
RUN AP [%]	Actual Position	Actual position of the valve indicated as %.
RUN TP [%]	Target Position	Target position in %
RUN dV [%]	Deviation Value	Deviation between target position and actual position.
RUN IV	Integral Output Value	Accumulated integral output value
RUN MV	Manipulator Value	Digital input value applied to I/P converter
RUN TEMP[°C]	Temperature	Internal temperature of positioner in °C.
** dS XXXX (PS XXXX)	**: Alarm Code  dS: Device Status PS: Process Status  XXXX: NE107 or Abbreviation of each alarm	The status of the current process or positioner is shown with English letter XXXX. Normally, GOOD is displayed when there is no problem, but alarm or status is displayed in abbreviated words (MNTR, FAIL, OUTS, FUNC and so on) along with NE107 symbol when a state change or alarm occurs. Any of the alarms is displayed alternately each time the ENTER button is pressed. (See 9.15 Status and Alarm Code)
RUN IN [mA]	Input Current	Current input signal in mA
RUN SP [%]	Set Position	Input signal converted into %

# When there is no alarm.



# When an alarm occurs.

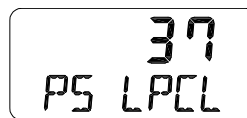

# Explaining contents of alarm display

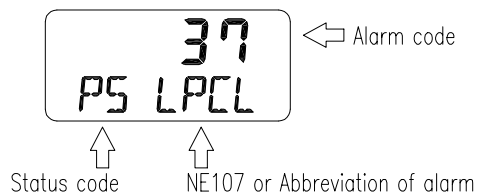

9.5 Configuration and Operation

The Table below shows the eight Configuration/Operation menus, each submenu, ranges for each parameter, and initial factory settings. The words shown in [ ] for each menu represent the abbreviations of each word displayed when operating the LCD screen.

Level 1	Level 2	Range	Initial factory setting
Calibration [CALIb]	Acting Type	[SINGLE, dOUbLE]	
	Auto Calibration 1 [AUTO 1]		
	Auto Calibration 2 [AUTO 2]		
	Travel Zero [TVL ZERO]		
	Travel End [TVL ENd]		
Manual Operation [MAN OPER]	Manual Operation by Set Position [MAN SP]		
	Manual Operation by Manipulator Value [MAN MV]		
Control Parameters [CTL PARM]	Dead Band [dEAdbANd]	0.1 ~ 10.0 [%]	0.3 %
	Proportional Gain, Upward [KP UP]	0.1 ~ 50.0	1
	Proportional Gain, Downward [KP dN]	0.1 ~ 50.0	1
	Integral Gain, Upward [TI UP]	0.1 ~ 50.0	1
	Integral Gain, Downward [TI dN]	0.1 ~ 50.0	1
	Differential Gain, Upward [Kd UP]	0.1 ~ 50.0	1
	Differential Gain, Downward [Kd dN]	0.1 ~ 50.0	1
	Gap [GAP]	0.1 ~ 5.0 [%]	1 %
	GP [GP]	0.1 ~ 5.0	1
	GI [GI]	0.1 ~ 5.0	1
	GD [Gd]	0.1 ~ 5.0	1
	Auto Dead Band Mode [AUTO db]	oFF, [0%]	oFF
	Performance Mode [PER]	Stable, Normal, Fast [STbL, NORM, FAST]	NORM
Input Configuration [IN CFG]	Signal Direction [SIG]	Normal, Reverse [NORM, REVS]	NORM
	Split Range Mode [SPLIT]	4 ~ 20, 4 ~ 12, 12 ~ 20, Custom [4.20, 4.12, 12.20, CST]	4.20
	Custom Split Range Zero [CST ZERO]	4 ~ 20.0 mA]	4 mA
	Custom Split Range End [CST ENd]	4 ~ 20.0 [mA]	20 mA

Level 1	Level 2	Range	Initial factory setting
Input Configuration [IN CFG]	Characterization [CHAR]	Linear, Quick Open, Equal Percent, User Set 5point, User Set 21point [LIN, QO, EQ, U5, U21]	LIN
	User Set Characterization 5p [USER 5P]	0 ~ 110[%]	0 %, 25 %, 50 %, 75 %, 100 %
	User Set Characterization 21p [USER 21P]	0 ~ 110[%]	0 %, 5 %, 10 %, ... 95 %, 100 %
	Tight Shut Open [TSHUT OP]	0 ~ 100 [%]	100.0 %
	Tight Shut Close [TSHUT CL]	0 ~ 100 [%]	0.3 %
	SP Ramp Up Rate [RAMP UP]	oFF, 0.1 ~ 100 [%]	oFF
	SP Ramp Down Rate [RAMP dN]	oFF, 0.1 ~ 100 [%]	oFF
Output Configuration [OUT CFG]	Position Transmitter Direction [PTM]	[NORM, REVS]	NORM
	Position Transmitter Zero [PTM ZERO]	0 ~ 100.00 [%]	
	Position Transmitter End [PTM ENd]	0 ~ 100.00 [%]	
	HART Feedback Direction [HT]	[NORM, REVS]	NORM
	Back Calculation [bACKCAL]	[oFF, on]	oFF
Device Configuration [dEV CFG]	Action [ACT]	[dIR, REVS]	REVS
	Linear Lever Type [LEVT]	[STd, AdP]	STd
	Linear Interpolation [ITP]	[oFF, on]	on with Linear oFF with Rotary
	Write Protect [W]	[UNLOCK, LOCK]	UNLOCK
	View Mode [VI]	[NORM, REVS]	NORM
	Polling Address [POL Addr]	[0 ~ 63]	0
	Factory Reset [dEFAULT]		
	Self-Test [SELFTEST]		
Diagnosis [dIAGNO]	Process Status [PS]	GOOd, FAIL, FUNC, OUTS, MNTR	GOOd
	Device Status [dS]	GOOd, Refer to 9.15 Status and Alarm Code.	GOOd
	View Monitoring Counts [VI CNTS]	[CYCL CNT, TVL ACUM, OPER CNT, FOP CNT, FCL CNT]	0
	Diagnosis Limit Configuration [LIMIT CFG]	TVL HI, TVL LO, dV TIME, dV db, AL TVLH, AL TVLL,	100 %, 0 %, 10 sec, 5.0 %, oFF, oFF,
	Reset Alarm Status [RST ALRM]		

Level 1	Level 2	Range	Initial factory setting
Diagnosis [DIAGNO]	View Event Log [EVT LOG]	RECORd 0 - 19	0
	View PST Result Record [PST RSLT]	RECORd 1 - 10	bLANK
	PST Configuration [PST CFG]	INTERVAL, START PO, TOL, TARGET, HOLD TM, LIMT TM, PRAMP UP, PRAMP dN, NEXT PST	365 d, 100 %, 5 %, 90 %, 5 sec, 10 sec, 0 %, 0 %, oFF
	Run PST [PST NOW]		
	PST Schedule [PST SCHd]	on, oFF	oFF
	Information [INFO]	Model Name [YT3300*]	
Firmware Version [SOFT VER]		*.*.*	Program current version
Download Date		YYYYMMDD	Program input date
Run Time [RT]		*.* RT *d	
Upward Stroke Time [FULL OP]		*.*	
Downward Stroke Time [FULL CL]		*.*	
Position Sensor Type [PSNT]		PTN, NCS	
Absolute Position in Angle [AbS ANGL]		***.*°	
HART Protocol Revision [HART VER]	7	7	

The Table below identifies the range and initial factory settings of each parameter for Menu Level 2 and Menu Level 3 where the menu hierarchy has been lowered by one level.

Level 2	Level 3	Range	Initial factory setting
View Monitoring Counts [VI CNTS]	Cycle Count [CYCL CNT]	0 ~ 4,200,000,000	
	Travel Accumulated [TVL ACUM]	0 ~ 168,000,000 [%]	
	Operating Count [OPER CNT]	0 ~ 4,200,000,000	
	Full Open Count [FOP CNT]	0 ~ 4,200,000,000	
	Full Close Count [FCL CNT]	0 ~ 4,200,000,000	
LIMT CFG	Travel Hi Limit [TVL HI]	0 ~ 120 [%]	100 %
	Travel Lo Limit [TVL LO]	-10 ~ 50 [%]	0 %
	Travel Hi Limit Alarm Enable [AL TVLH]	oFF, on	oFF
	Travel Lo Limit Alarm Enable [AL TVLL]	oFF, on	oFF

Level 2	Level 3	Range	Initial factory setting
PST CFG	PST Interval [INTERVAL]	1 ~ 365 [days]	365
	PST Starting Position [START PO]	0 ~ 100 [%]	100 %
	PST Tolerance [TOL]	0.1 ~ 10 [%]	5 %
	PST Target Position [TARGET]	0 ~ 100 [%]	90 %
	PST Hold Time [HOLD TM]	1 ~ 60 [sec]	5 sec
	PST Limit Time [LIMIT TM]	1 ~ 300 [sec]	10 sec
	PST Ramp Up Rate [PRAMP UP]	oFF, 1 ~ 100 [%/sec]	oFF
	PST Ramp Down Rate [PRAMP dN]	oFF, 1 ~ 100 [%/sec]	oFF
	PST Time Remaining [NEXT PST]	oFF, 1 ~ 365 [days], 0 ~ 24 [hour]	oFF

9.6 Calibration (CALIb)

The calibration consists of five menus.

Calibration [CALIb]	Acting Type [SINGLE/ dOUBLE]	Set manually single or double acting by actuator type
	Auto Calibration 1 [AUTO 1]	Calibration on the zero and end points of the valve
	Auto Calibration 2 [AUTO 2]	Calibration on all parameters required to operate the valve
	Travel Zero [TVL ZERO]	Manually adjust the zero point of the valve
	Travel End [TVL ENd]	Manually adjust the endpoint of the valve

Auto Calibration simplifies calibration without having to go through complex gain tuning. Once the current input between 4 and 20 mA is applied, it takes approximately 2-3 minutes to complete the automatic calibration, which may vary depending on the size of the actuator. There are two types of Auto Calibrations as shown below so that you select and use them as required.

	ZERO	END	P, I, D gain	RA, DA	BIAS
AUTO 1	O	O	X	X	X
AUTO 2	O	O	O	O	O

9.6.1 Acting Type (SINGLE / dDOUBLE)

This is used to change the settings of the positioner to SINGLE or dDOUBLE, depending on the actuator type. The setting of the SINGLE and dDOUBLE affects the automatic calibration, so it must be set carefully considering the actuator type.



**If the actual acting type of Actuator is different from the set value, it will cause a problem, so make sure that the actual acting type matches the set value.**

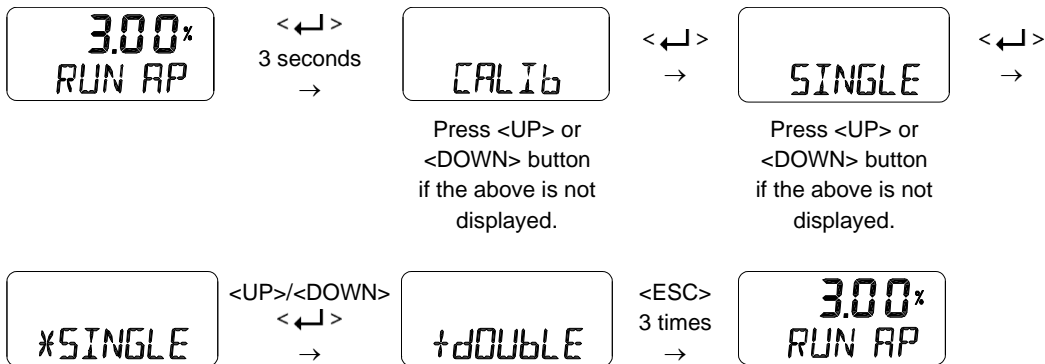

9.6.2 Auto Calibration 1 (AUTO 1)

AUTO 1 is used to set only the origin and end points. It does not change the PID and other parameter values that already have been set. This is usually used when the origin and end points of the already calibrated positioner have changed slightly.

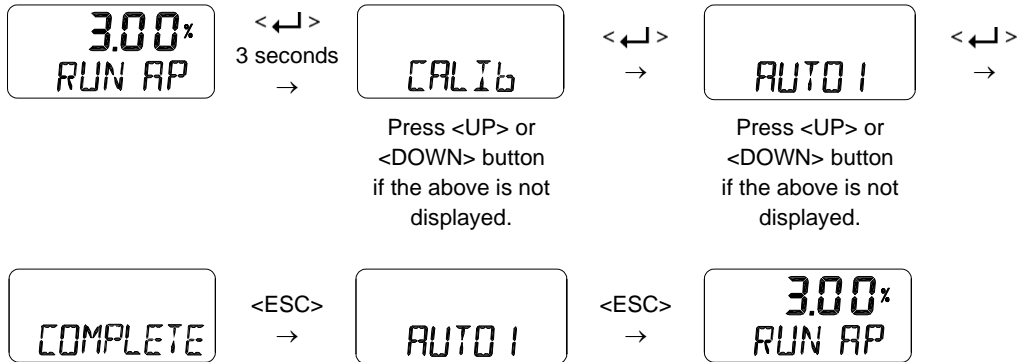

9.6.3 Auto Calibration 2 (AUTO 2)

AUTO 2 tunes up and then changes all parameters required for valve operation. Be sure to perform this AUTO 2 when installing the positioner on the valve for the first time or when reinstalling the positioner from the actuator.

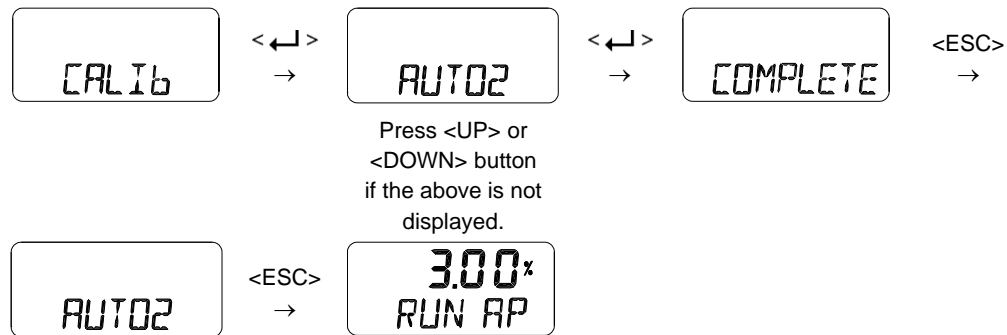

9.6.4 Travel Zero (TVL ZERO) and Travel end (TVL ENd)

This is a manual adjustment of the zero point or endpoint of the valve after auto calibration. Once you enter the TVL ZERO (or TVL ENd) setting, press the UP/DOWN button to change the zero point (or endpoint) of the valve, and then press the ENTER button to save it. The saved position is recognized as the zero (or endpoint) of the valve.

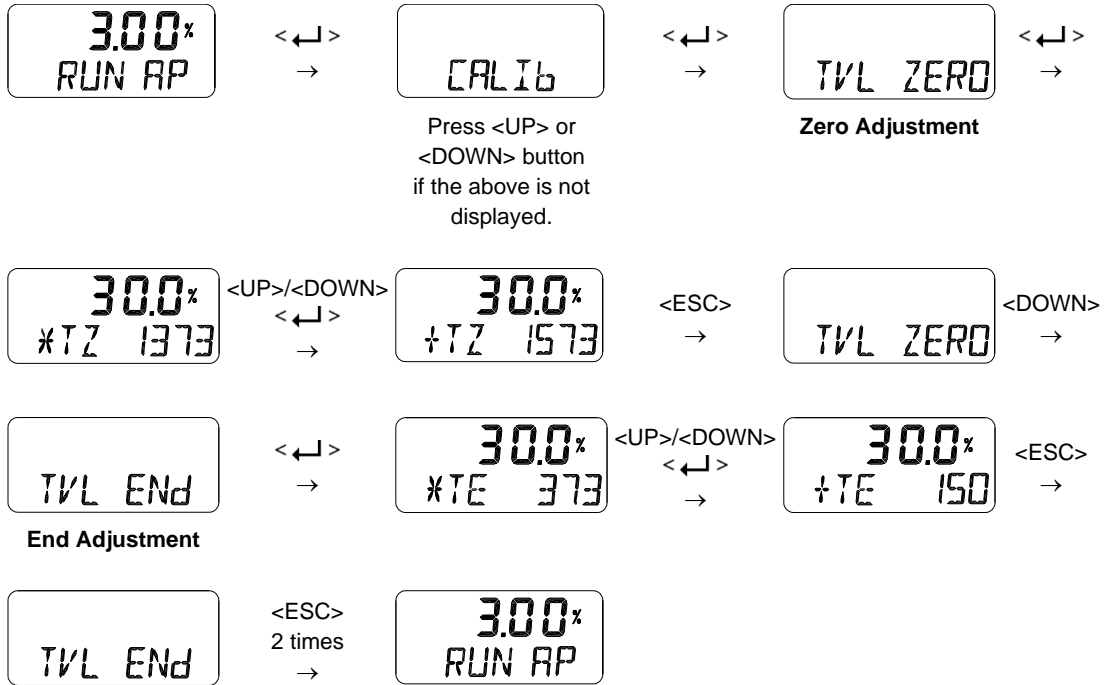

9.7 Manual Operation (MAN OPER)

It is used to manually raise or lower the valve stem by operating the UP or DOWN buttons. This can be used to observe the move of valve stem without any external input signals. When engaged, the current input signal to the positioner has no effect on the positioner.



**Manual operation may affect the process in service, so use this function when the process is down or when it is acceptable to shut down the process.**

9.7.1 Manual Operation by Set position (MAN SP)

The target position is incremented by the UP and DOWN buttons based on the currently entered set position values, which moves the stem of the valve up and down. Once out of the menu by <ESC>, the positioner is controlled again by an input signal.

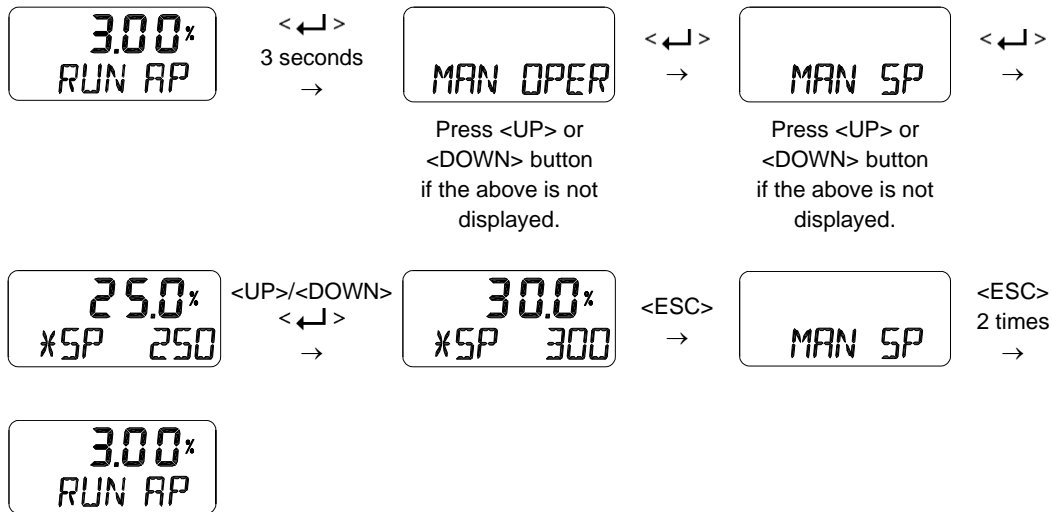

9.7.2 Manual Operation by Manipulator Value (MAN MV)

The input to I/P converter is incremented or decremented by the UP and DOWN buttons based on the currently entered I/P input value, which moves the stem of the valve up and down. Once out of the menu by <ESC>, the positioner is controlled again by an input signal.

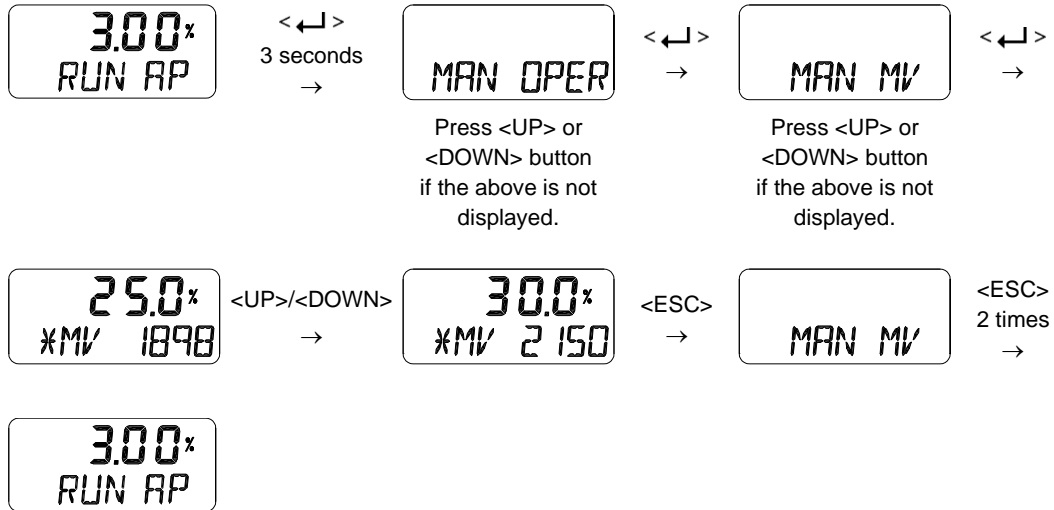

9.8 Control Parameters (CTL PARM)

Followings are the values changeable at the Control Parameters Mode.

- 1) Dead Band (dEAdbANd)
- 2) Forward P parameter (KP UP) and reverse P parameter (KP dN)
- 3) Forward Integral time parameter (TI UP) and reverse Integral time parameter (TI dN)
- 4) Forward D parameter (Kd UP) and reverse D parameter (Kd dN)
- 5) GAP Parameter (GAP)
- 6) GAP P Parameter (GP)
- 7) GAP I Parameter (GI)
- 8) GAP D Parameter (Gd)
- 9) Auto Dead band Mode (AUTO db)
- 10) Performance Mode (PER)

9.8.1 Dead Band (dEAdbANd)

Deadband indicates the size of the allowable deviation that is set near the target position. If the valve has large packing friction, this value can be adjusted and set accordingly to prevent the limit cycle caused by the friction. If the deadband is set to 0.5 %, its range is  $\pm 0.5\%$  of the target.

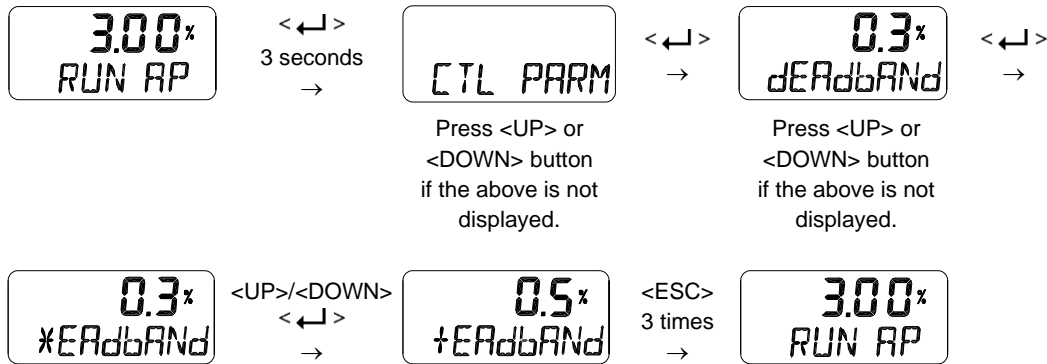

9.8.2 Forward P parameter (KP UP) and reverse P parameter (KP dN)

The KP parameter is the proportional control constant to the calibration signal to reduce the error between the target position and the current position, the KP UP is applied when the valve moves in the direction of increasing output air pressure, and KP dN is applied when the valve moves in the direction of venting output air pressure. A larger value of gains "KP UP" or "KP dN" moves the valve faster to reach a target position, but the valve tends to oscillate if set to high. In contrast, smaller gains improve stability, but make it slower to reach a target position.

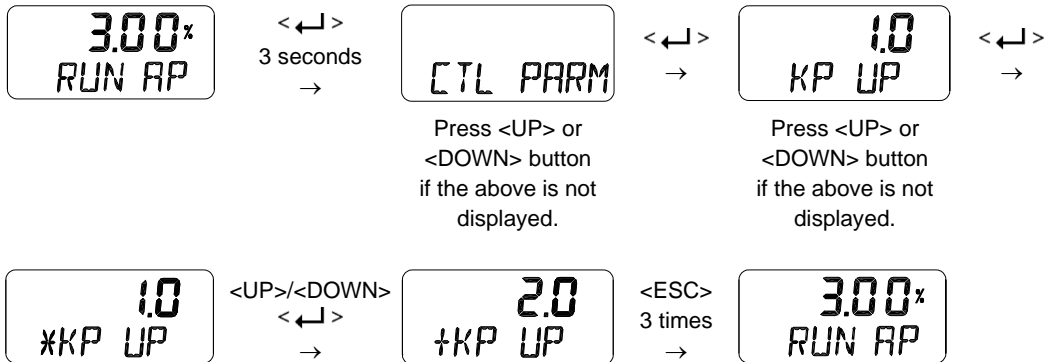

9.8.3 Forward Integral time parameter (TI UP) and reverse Integral time parameter (TI dN)

TI parameters are an integral value that add the error correction signal to the existing calibration signal, TI UP is applied when the valve moves in the direction of increasing the output air pressure, and TI dN is applied when the valve moves in the direction of decreasing the output air pressure. A smaller TI makes the valve faster to reach a target position and tends to cause oscillation.

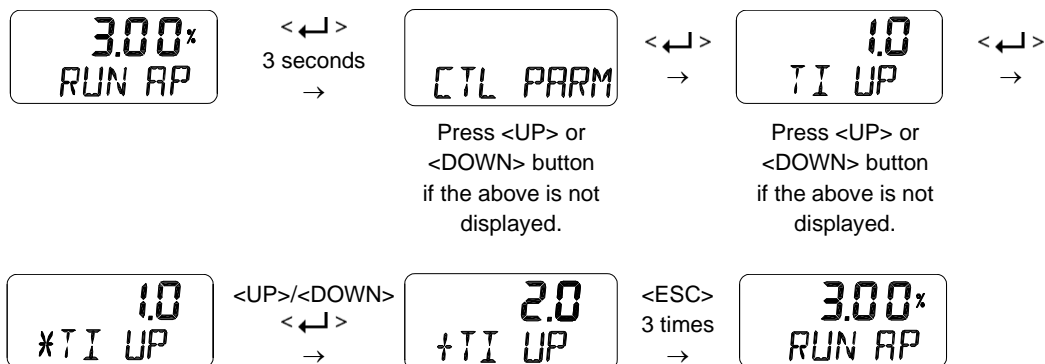

9.8.4 Forward D parameter (Kd UP) and reverse D parameter (Kd dN)

The Kd parameter is a differential value that adds the correction signal due to the rate of error to the existing calibration signal. Kd UP is applied when the valve moves in the direction of increasing output air pressure, and Kd dN is applied when the valve moves in the direction of decreasing output air pressure. A larger D value makes the valve hunting easier, and a smaller value can lead to poor linearity or dynamic properties.

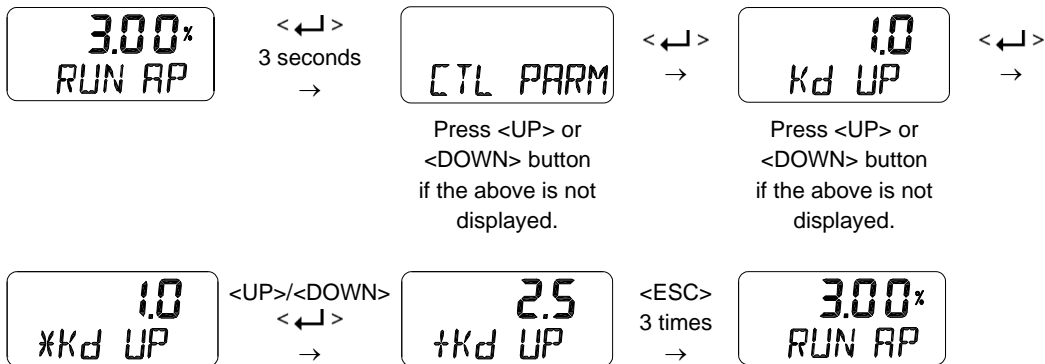

9.8.5 GAP Parameter (GAP)

The GAP parameter sets the control range at which Gap control begins. If the current position of the valve falls within the setting range GAP (%) relative to the final target position (target position ± GAP), Gap control operates along with PID Control. When the GAP control begins, the PID GAP parameters (GAP P, GAP I and GAP D) interacted with the PID parameters (KP, KI and KD) are applied to valve control.

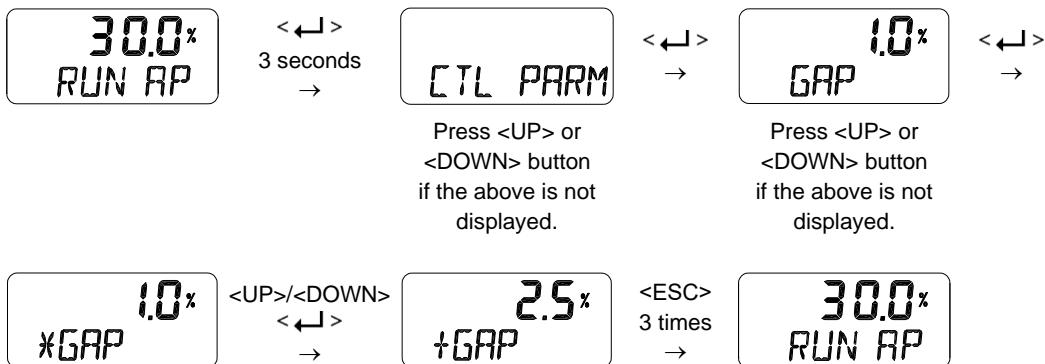

9.8.6 GAP P parameter (GP)

GP is a proportional gain. If the valve position is within the GAP parameter range, a proportion gain created based on KP and GP is applied to valve control.

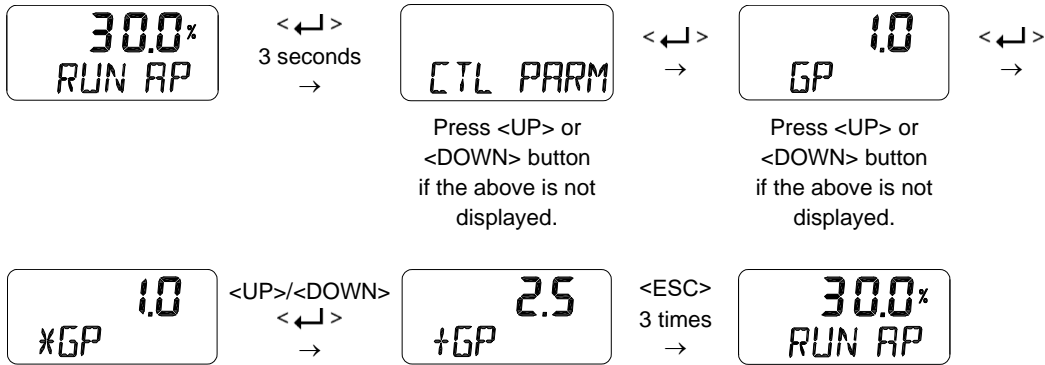

9.8.7 GAP I parameter (GI)

GI is an integral gain. If the valve position is within the GAP parameter range, an integral gain created based on 1/TI and GI is applied to valve control.

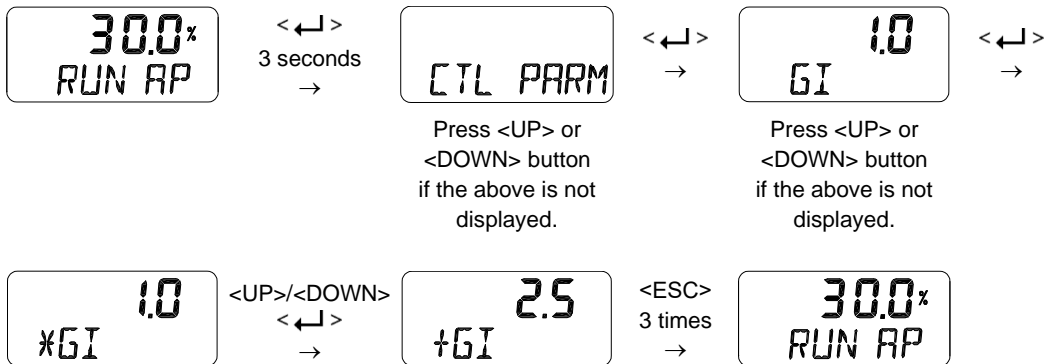

9.8.8 GAP D parameter (Gd)

Gd is a differential gain. If the valve position is within the GAP parameter range, a differential gain created based on Kd and Gd is applied to valve control.

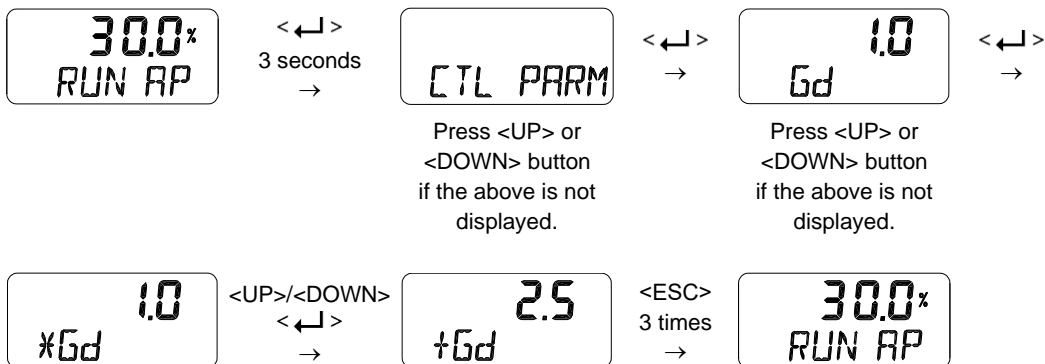

9.8.9 Auto Dead band Mode (AUTO db)

This function is used to suppress a hunting for valves with high static friction. The initial value is OFF and it shall be set to 0 % to activate the auto dead band automatically. The value is changed to a proper value once this mode is activated.

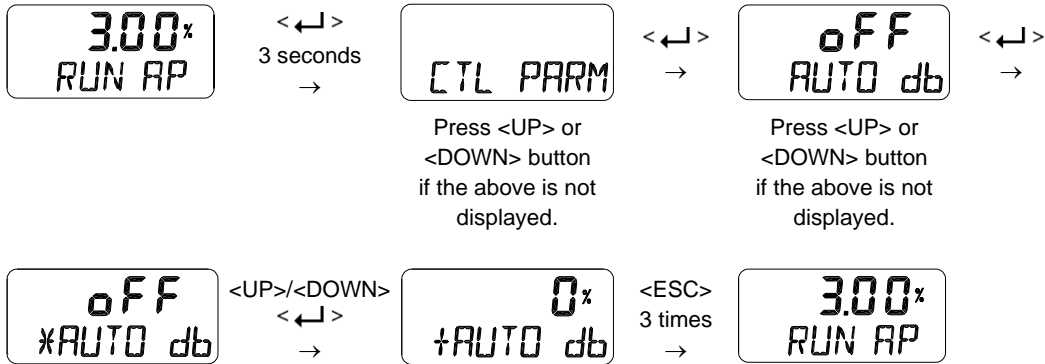

9.8.10 Performance Mode (PER)

This mode has three modes of operation: Stable, Normal, and Fast that allow you to select the required responsiveness. The performance modes indicate the response characteristics from slow response to quick response in the order of Stable, Normal and Fast.

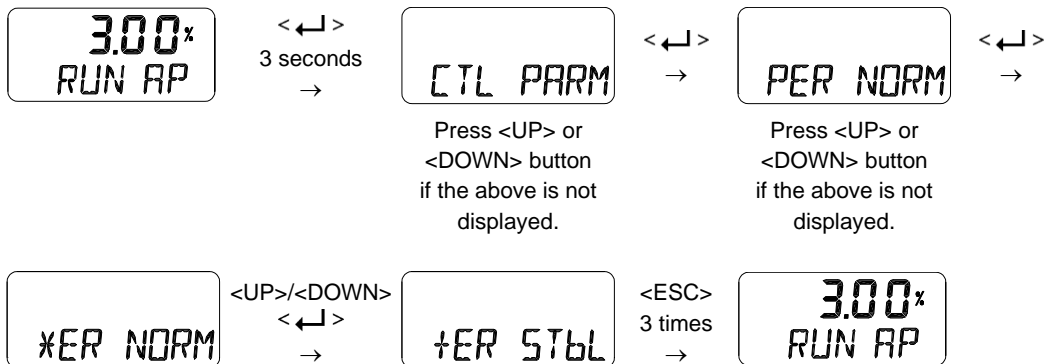

9.9 Input Configuration (IN CFG)

Followings are the values changeable at the Input Configuration Mode.

- 1) Signal Direction (SIG NORM / REVS)
- 2) Split Range Mode (SPLIT)
- 3) Custom Split Range Zero (CST ZERO)
- 4) Custom Split Range End (CST ENd)
- 5) Characterization Curves (CHAR)
- 6) User Set Characterization 5 Points (U5)
- 7) User Set Characterization 21 Points (U21)
- 8) Tight Shut Open (TSHUT OP)
- 9) Tight Shut Close (TSHUT CL)
- 10) Target Position Ramp Up Rate (RAMP UP) and Target Position Ramp Down Rate (RAMP dN)

9.9.1 Signal Direction (SIG NORM / REVS)

This function changes the action type of the valve, NORM or REVS. if NORM is selected, the air is completely released through output port 1 of the positioner when 4 mA is applied, and the maximum air pressure is loaded to the actuator through output port 1 when 20 mA is applied. If set to REVS, the maximum air pressure is loaded to the actuator via output port 1 when an input current of 4 mA is applied to the positioner.

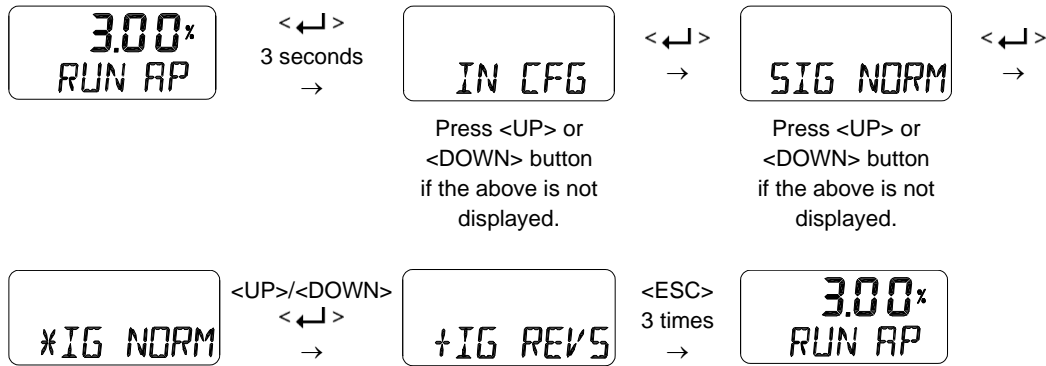

### 9.9.2 Split Range Mode (SPLIT)

This is used to set the range of the input signal to control the entire stroke of the valve. You can select one of the four input signals that consists of 4 ~ 20 mA, 4 ~ 12 mA, 12 ~ 20 mA, and user settings (Custom, CSt). 4 ~ 20 mA is the factory setting.

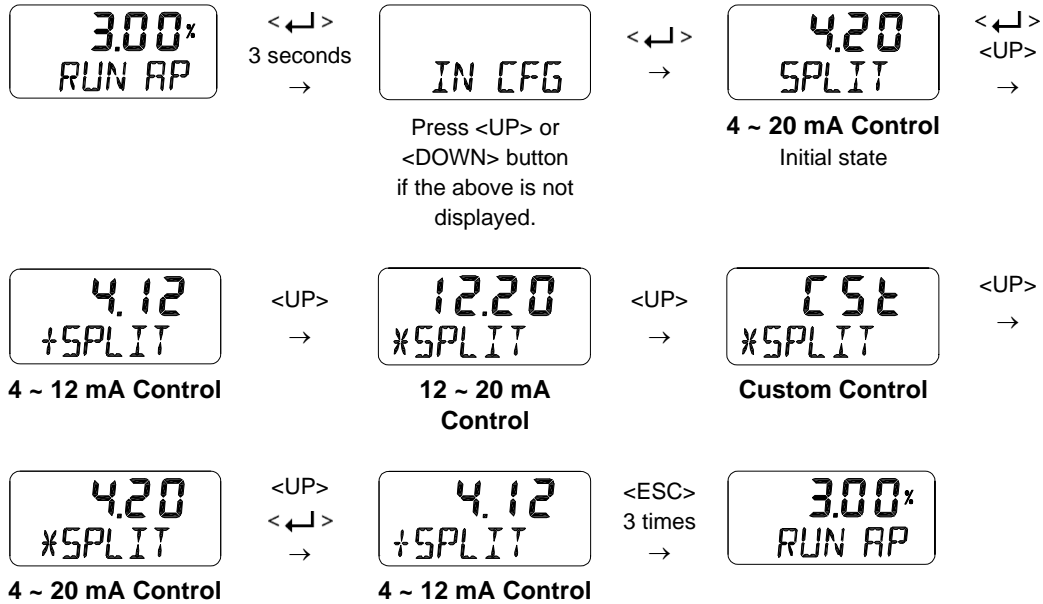

### 9.9.3 Custom Split Range Zero (CST ZERO)

It is used to set the current corresponding to the zeropoint when the valve position of 0 to 100 % is controlled by the user-set CUSTOM. For example, if the valve is controlled by 6 ~ 20 mA instead of 4 ~ 20 mA, CST ZERO is 6 mA. However, the difference of the current between the origin point and the endpoint must be greater than 4 mA.

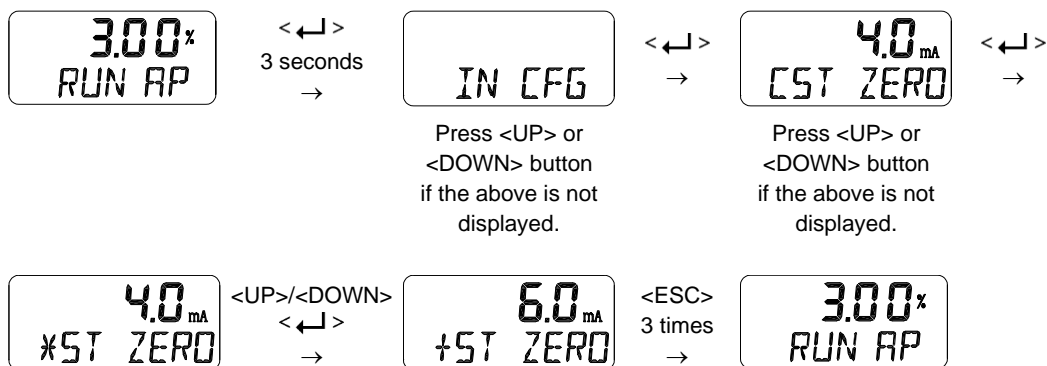

This function is activated by saving the Split Range Mode (SPLIT) of above Section 9.9.2 as "CSt".

9.9.4 Custom Split Range End (CST END)

It is used to set the current corresponding to the endpoint when the valve position of 0 to 100 % is controlled by the user-set CUSTOM. For example, if the valve is controlled by 4 ~ 18 mA instead of 4 ~ 20 mA, CST END is 18 mA. However, the difference of the current between the origin point and the endpoint must be greater than 4 mA.

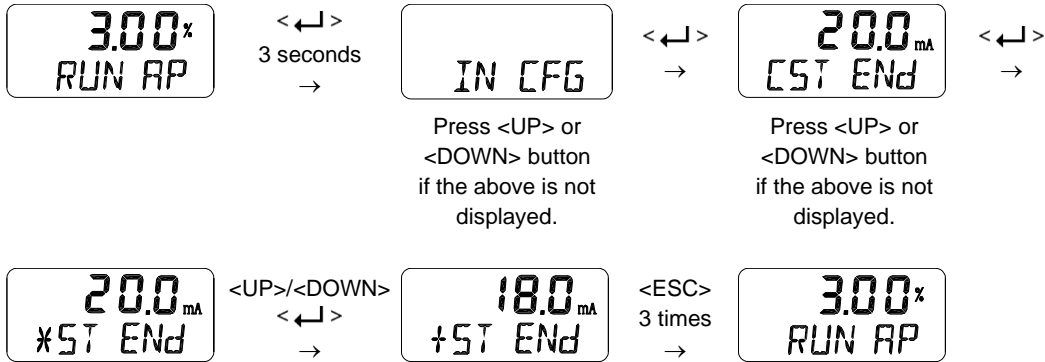

This function is activated by saving the Split Range Mode (SPLIT) of above Section 9.9.2 as “CSt”.

9.9.5 Valve Flow Characterization Curves (CHAR)

The flow characteristic curve of valve is available by selecting one of the following: Linear(LIN), Quick Open(QO), Equal Percentage(EQ), User Set Characterization 5 Points (U5) and User Set Characterization 21 Points(U21).

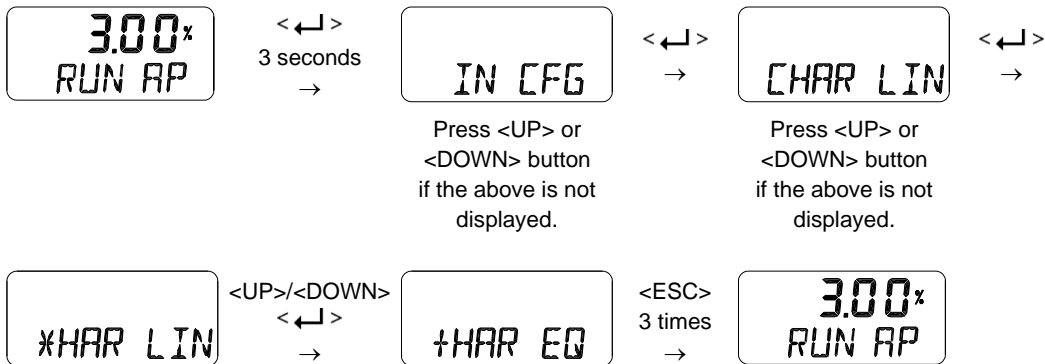
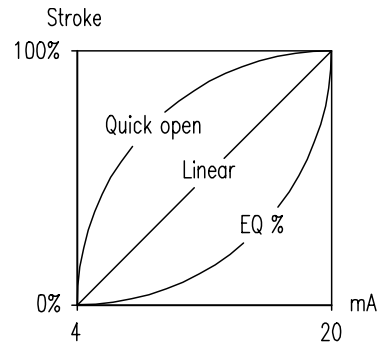

9.9.6 User Set Characterization 5 Points (U5)

A total of 5 target positions are set every 4 mA intervals. When shipped from the factory, the initial positions are P0 (4 mA, 0 %), P1 (8 mA, 25 %), P2 (12 mA, 50 %), P3 (16 mA, 75 %), and P4 (20 mA, 100 %). User can change all 5 points or only change partially and exit the menu by pressing <ESC> button.

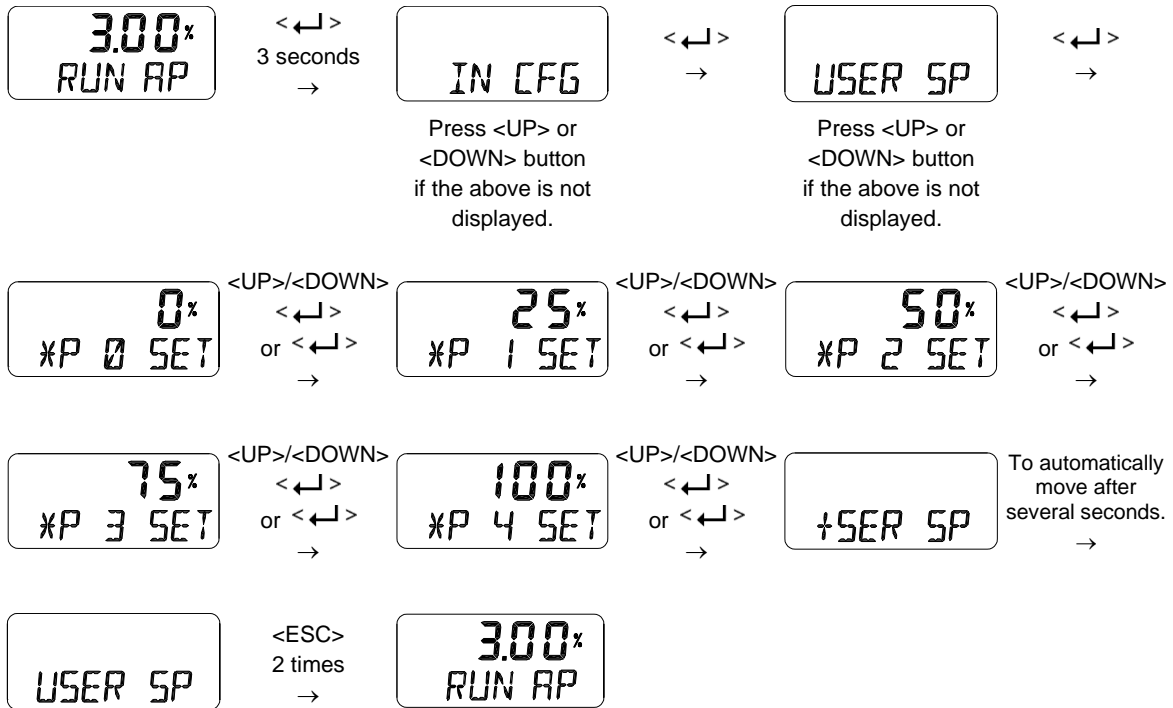

This function is activated by saving the Valve Flow Characterization Curves (CHAR) of above Section 9.9.5 as "U5".

9.9.7 User Set Characterization 21 Points (U21)

A total of 21 target points can be set every 0.8 mA intervals. When shipped from the factory, the initial P0 (4 mA, 0 %), P1 (4.8 mA, 5 %), P2 (5.6 mA 10 %), - - -, P19 (19.2 mA, 95 %), and P20 (20 mA, 100 %). For example, a characteristic curve below can be made through the settings of P1 to P20. User can change all 21 points or only change partially and exit the menu by pressing <ESC> button.

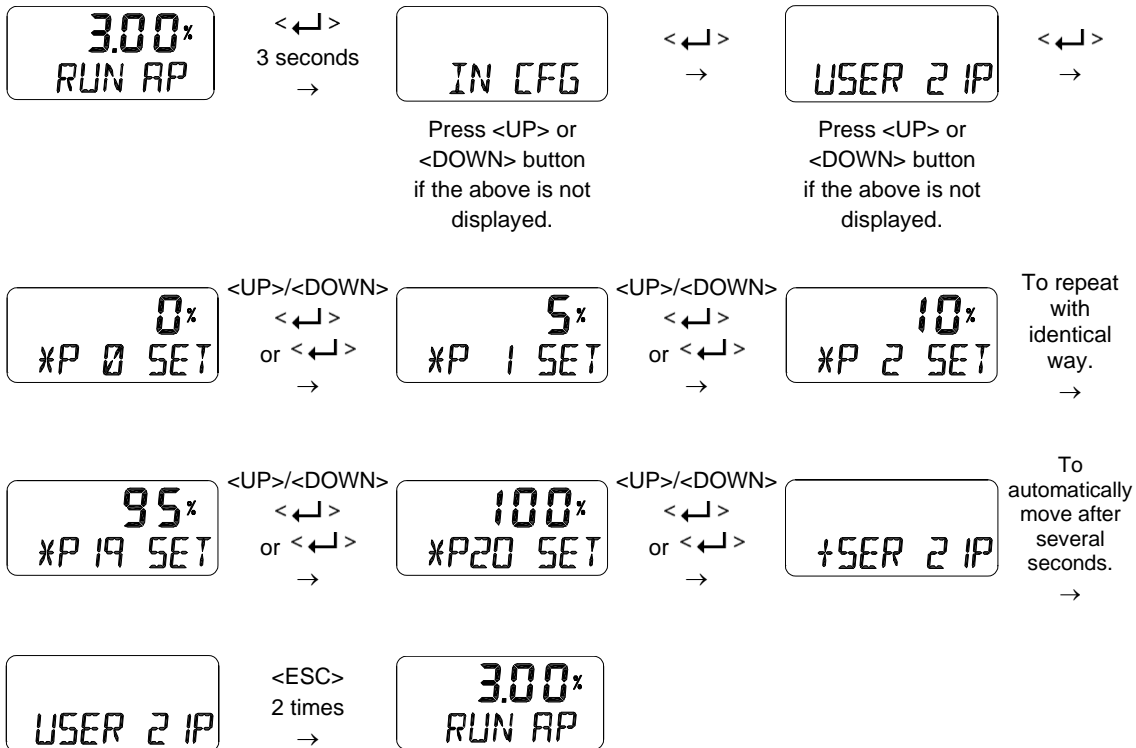
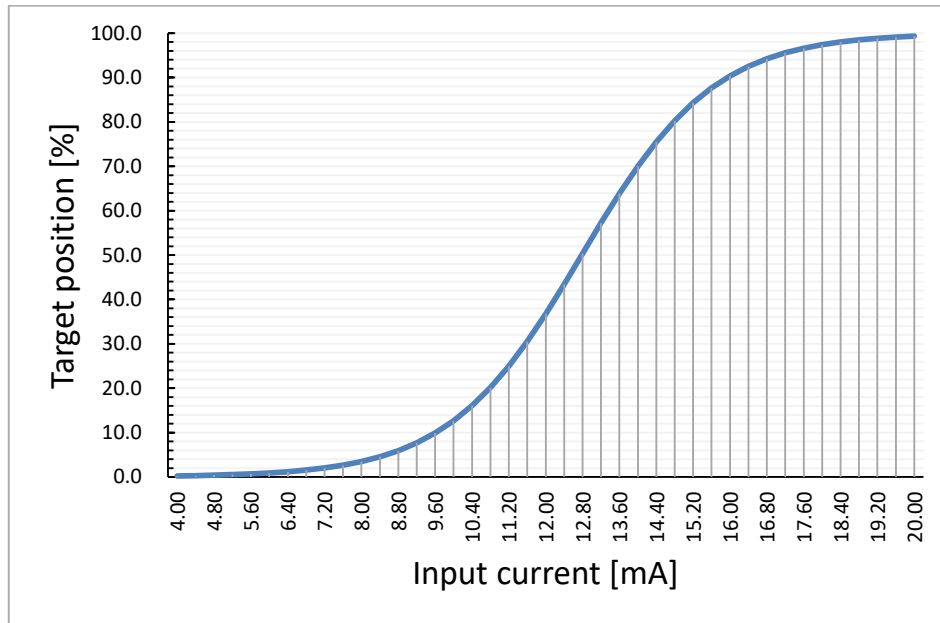

This function is activated by saving the Valve Flow Characterization Curves (CHAR) of above Section 9.9.5 as "U21".

9.9.8 Tight Shut Open (TSHUT OP)

It is used to ensure that the valve is fully opened with a large force. When the input signal SP is greater than the value set in the TSHUT OP, all available force is applied to OUT 1 port to tightly open the valve. If the input current of 4 mA is 0% of valve position and 20 mA is 100% of valve position, and the Tight Shut Open value is set to any position less than 100 % (e.g. 95 %), then the valve stroke will be 100 % immediately when the input signal is over the set value (e.g. 95 %). A full supply pressure applied to the actuator via the OUT1 port prevents leakage of the valve by shutting the valve tightly. However, when the value is set to 100 %, Tight Shut Open function doesn't work.

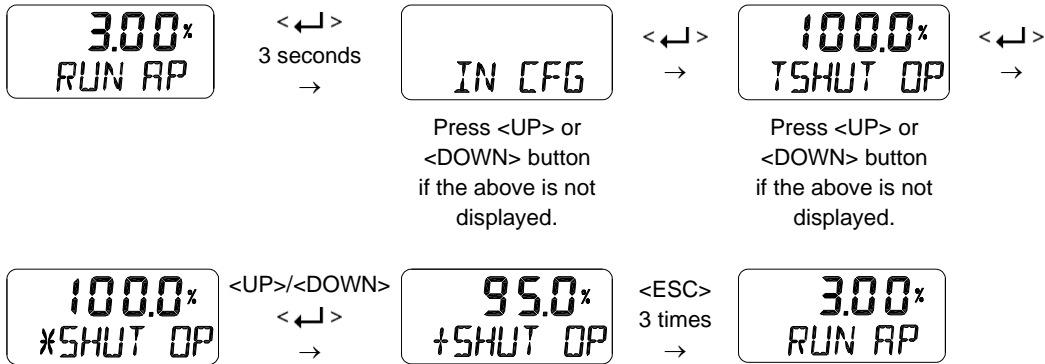

9.9.9 Tight Shut Close (TSHUT CL)

It is used to ensure that the valve is fully closed with a large force. When the input signal SP is smaller than the value set in the TSHUT CL, air pressure is vented through OUT 1 port to tightly close the valve. If the input current of 4 mA is 0 % of valve position and 20 mA is 100 % of valve position, and the Tight Shut Close value is set to any position larger than 0 % (e.g. 5 %), then the valve stroke will be 0 % immediately when the input signal goes below the set value (e.g. 5 %). The air venting from the actuator via the OUT1 port prevents leakage of the valve by shutting the valve tightly. However, when the value is set to 0 %, Tight Shut Close function doesn't work.

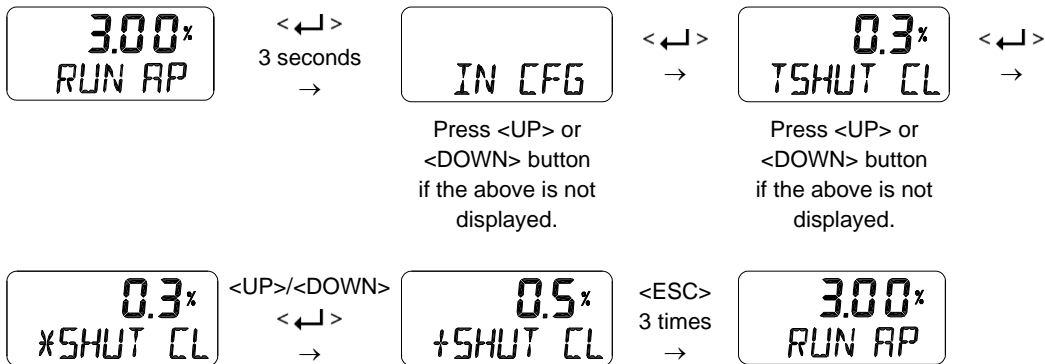

The following graph shows the operation of the valve stroke when the input signal corresponding to Tight Shut Open or Tight Shut Close is applied to the device.

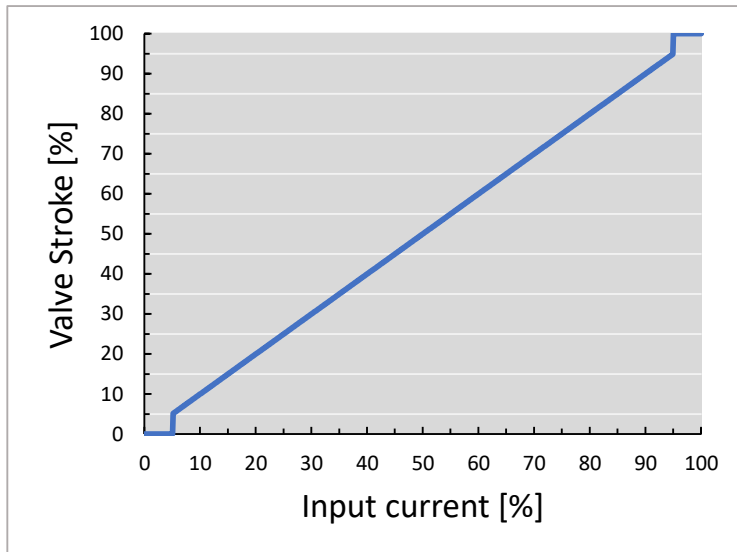

9.9.10 Target Position Ramp Up Rate (RAMP UP) and Target Position Ramp Down Rate (RAMP dN)

It is used to prevent the valve from moving too fast when the process to be controlled is too sensitive to rapid changes in flow or pressure. The unit of setting is %/sec. If you want to move 100 % of the stroke for about 5 seconds, set it to 20 [%/sec]. The rising and falling speed can be set independently, and the valve will move to the target position as soon as possible when this function is switched off.

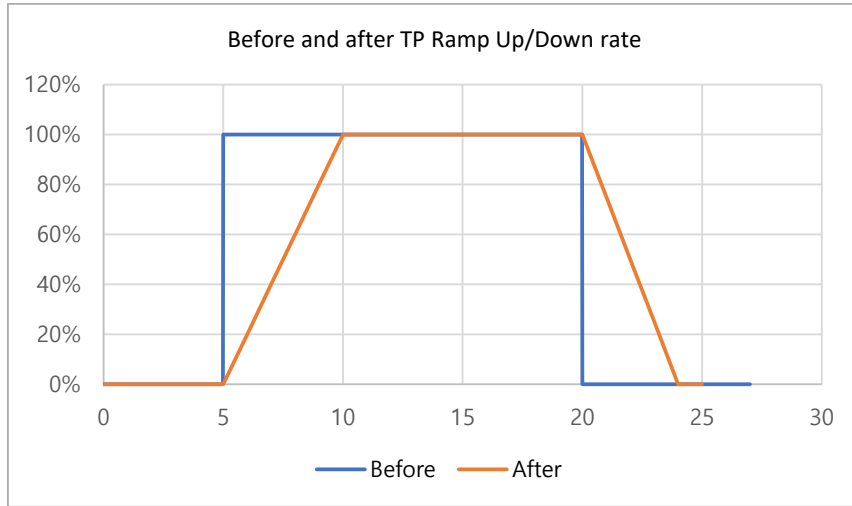

The curves below show the target position (red) and the actual position (blue) of the valve after applying SP Ramp Up/Down rate.

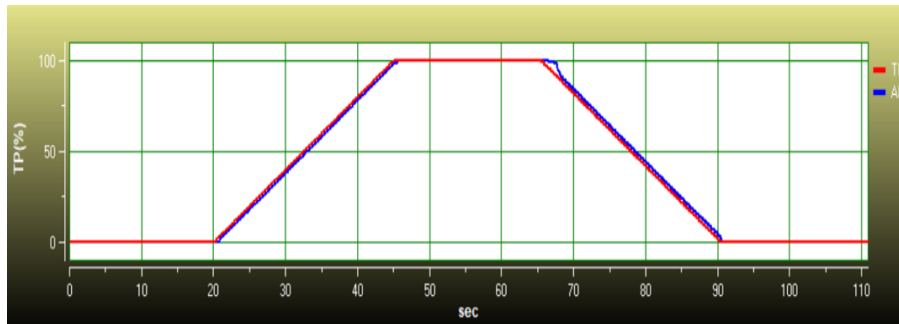

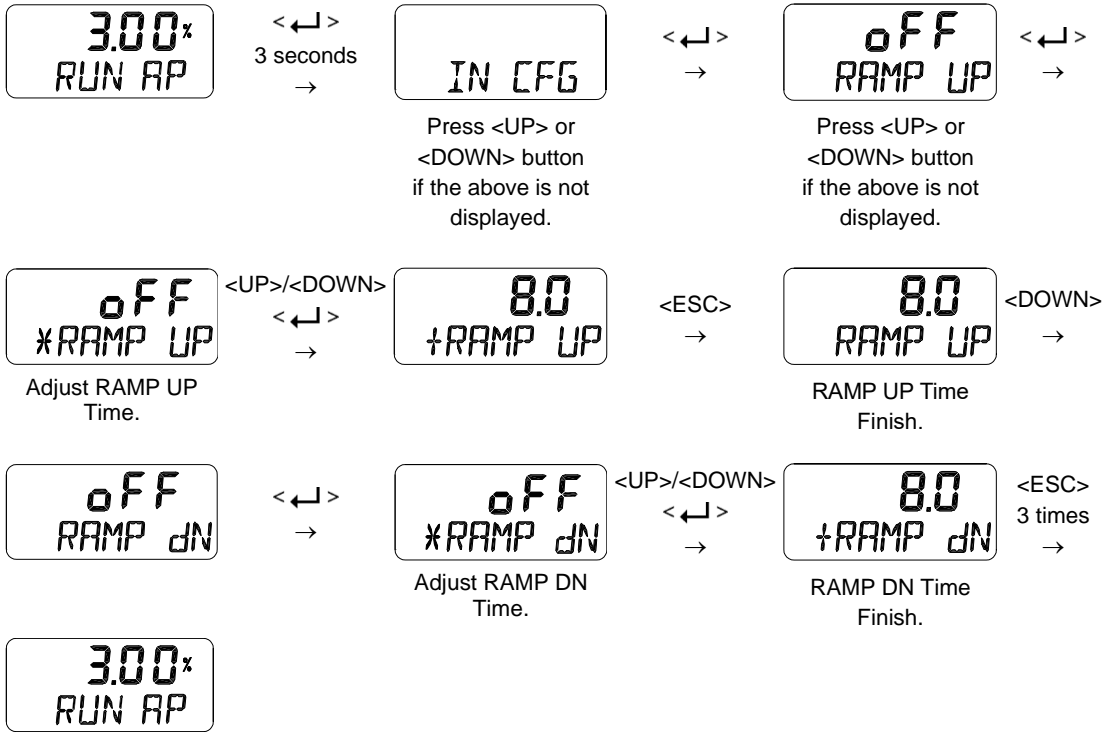

9.10 Output Configuration (OUT CFG)

Followings are the values changeable at the Output Configuration Mode.

- 1) Position Transmitter Direction (PTM NORM / REVS)
- 2) Position Transmitter Zero / End (PTM ZERO / ENd)
- 3) HART Feedback Direction (HT NORM / REVS)
- 4) Back Calculation (bACKCAL off / on)

9.10.1 Position Transmitter Direction (PTM NORM / REVS)

The analog feedback signal from the positioner can be changed to normal (NORM) or reverse (REVS), which means they are the same or reversed direction as the actual position.

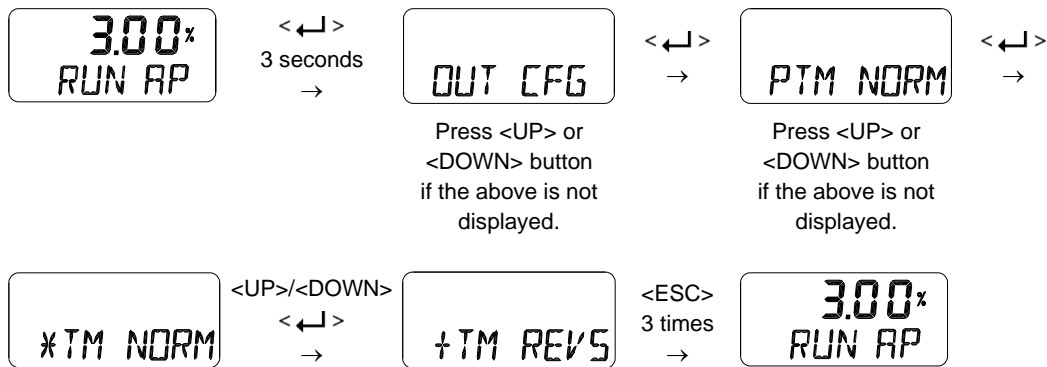

9.10.2 Position Transmitter Zero / End (PTM ZERO / ENd)

ZERO adjusts the zero point of the position transmitter (4 mA feedback), and ENd adjusts the end point of the transmitter (20 mA feedback). This is used when the analog output signal needs to be feedbacked differently than the actual position of the valve, or to be adjusted a little. A measuring instrument such as an ampere meter is needed to view the analog output signal, and it should be connected as shown below.

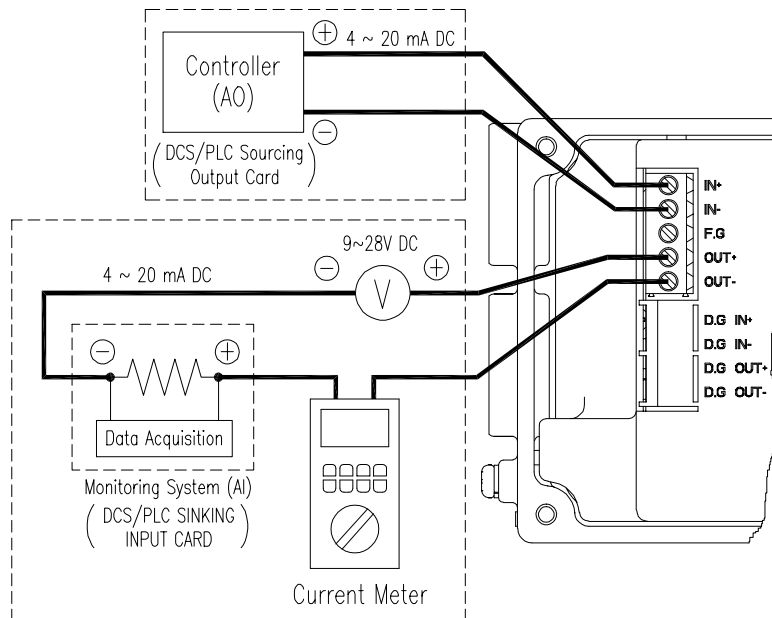
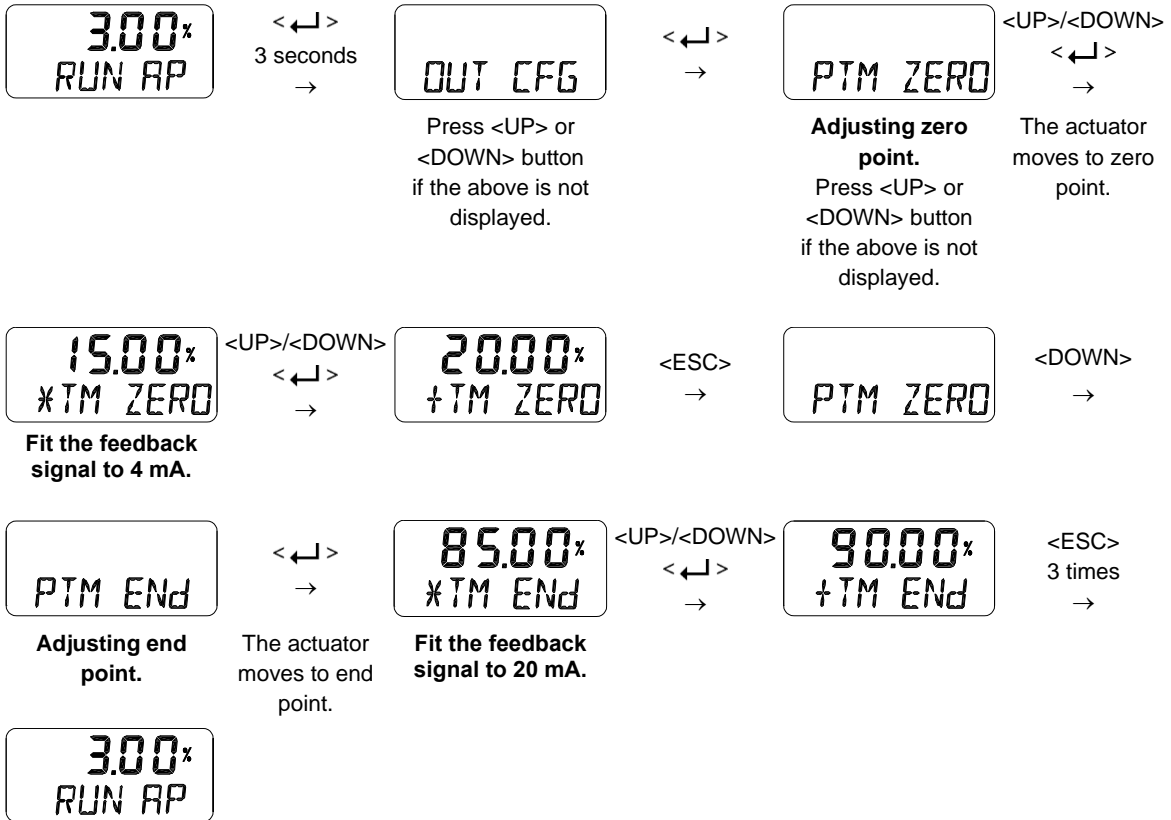
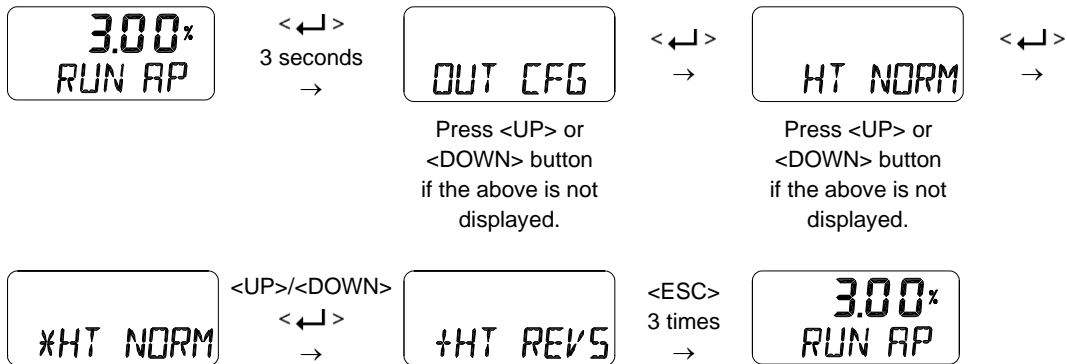

Fig. 9-3: Setting transmitter



### 9.10.3 HART Feedback Direction (HT NORM / REVS)

The feedback signal from the HART communication output of the positioner can be output in the same direction or the reversed direction as the actual position of the valve. NORM or REVS is selected.



9.10.4 Back Calculation (bACKCAL OFF / on)

This function recalculates the output "RUN AP" value changed by the flow characteristics setting mode to display it linearly proportional to actual input current. For example, if the flow characteristic mode is set from "LIN" to "EQ", when an input current value of 8 mA (25 %) is applied, the target position is changed to 6.25 % and "RUN AP" is displayed as 6.25 % after the move. If you change the bACKCAL from OFF to ON, the "RUN AP" is displayed as 25 %.

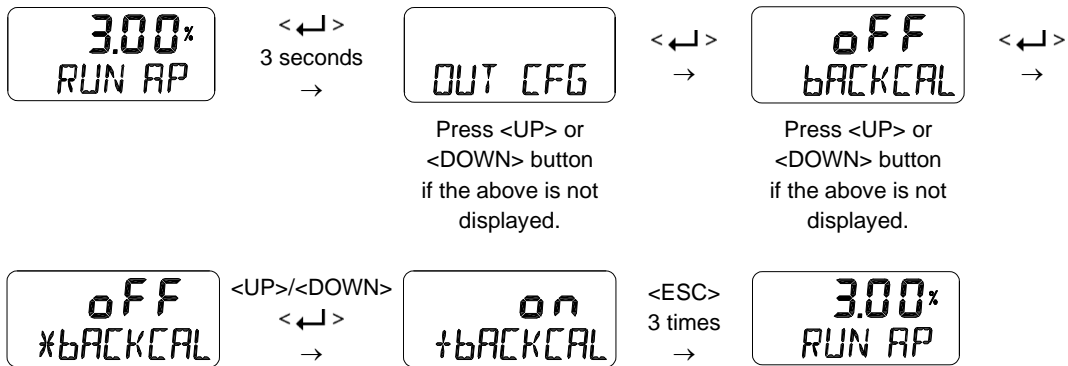

9.11 Device Configuration (dEV CFG)

Followings are the values changeable at the dEV CFG Mode.

- 1) Action Setting (ACT REVS / dIR)
- 2) Linear Lever Type (STd / AdT)
- 3) Linear Interpolation (ITP oFF / on)
- 4) Lock of Parameters (Write Protect, W UNLOCK / LOCK)
- 5) Actual Position View Mode (View Mode, VI NORM / REVS)
- 6) Polling address setting (POL Addr 0 ~ 63)
- 7) Factory Reset (dEFAULT oFF / on)
- 8) Positioner Self-Test (SELFTEST)

9.11.1 Action Setting (ACT REVS / dIR)

Reverse Action (REVS) or Direct Action (dIR) are automatically set by performing "AUTO 2" within the Auto Calibration function. However, this function is used when the user requires to change ACT REVS or ACT dIR to other action. Changing the action from Reverse Action (REVS) to Direct Action (dIR) or Direct Action (dIR) to Reverse Action (REVS) will also change the Signal Direction (SIG), Position Transmitter Direction (PTM), HART Feedback Direction (HT) and View Mode (VI).

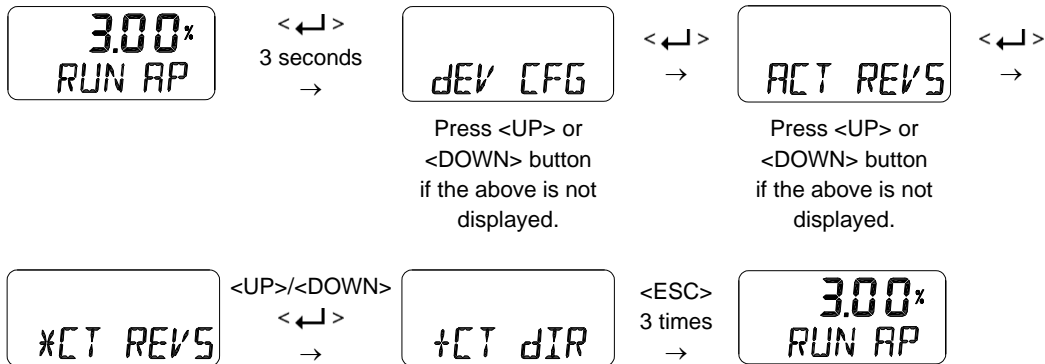

9.11.2 Linear Lever Type (LEVT STd / AdT)

Displays or changes current linear lever type into standard type or adapter type. If the Lever type mode is set correctly, the accuracy will be worse at ITP ON than at ITP OFF.

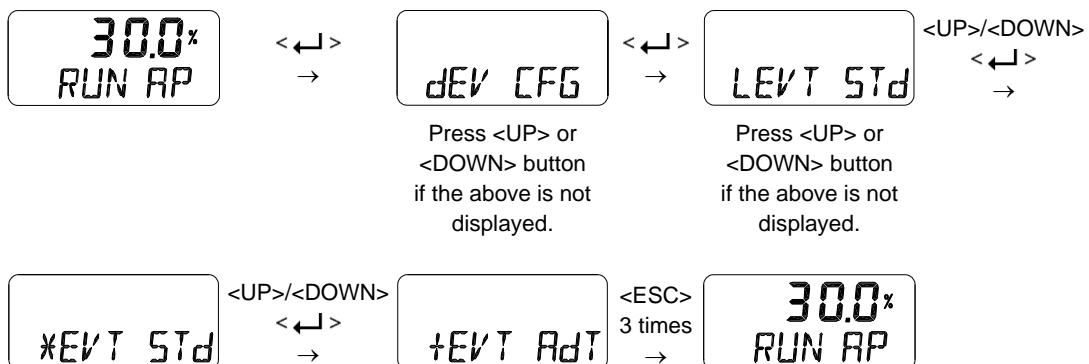

9.11.3 Linear Interpolation (ITP OFF / on)

ITP is used to compensate the linear motion of the actuator into rotary motion of the feedback lever. Following Auto Calibration, the ITP mode is set automatically to “on” when the angle range of the feedback lever is greater than 20 °, but it is set to oFF when this angle is less than 20 ° or rotary positioner is used.

The settings below are the process of manually changing the “ITP oFF” to the “ITP on”.

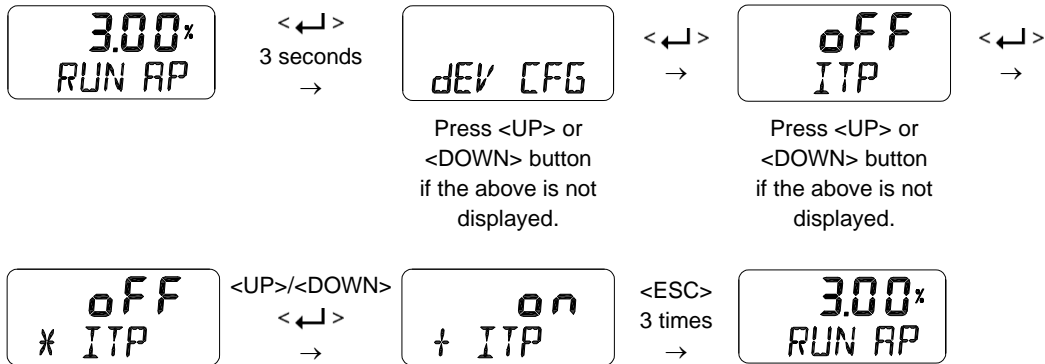

9.11.4 Lock of Parameters (Write Protect, W UNLOCK / LOCK)

This function is used to set (LOCK) or disable (UNLOCK) the lock for the parameters. Used to prevent the stored parameters from being changed.

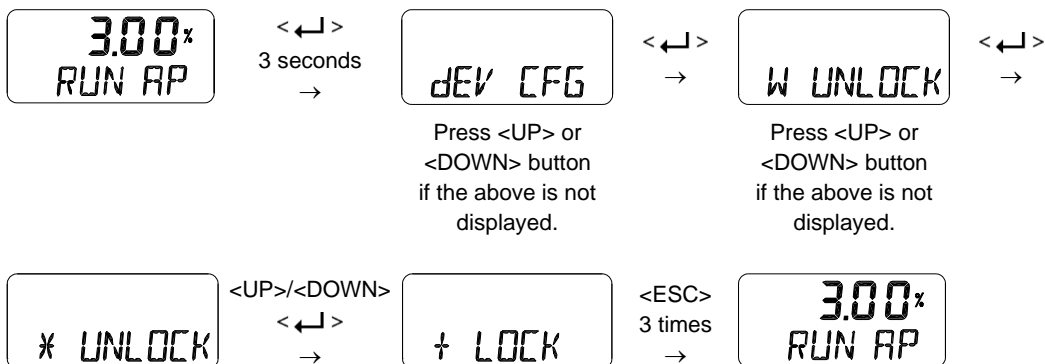

9.11.5 Actual Position View Mode (View Mode, VI NORM / REVS)

This function is used to set the "RUN AP" value on the LCD to be displayed as direct (NORM) or reversely (REVS) as the actual position of the valve.

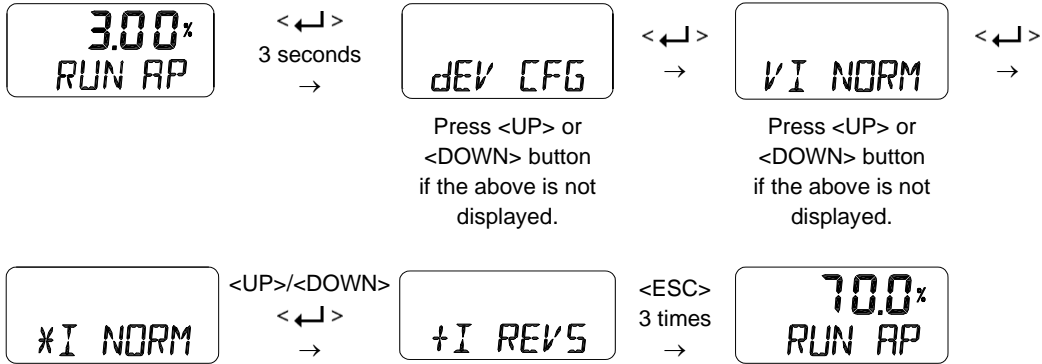

9.11.6 Polling address setting (POL Addr)

This function is used to set the address value of the positioner on HART(Highway Addressable Remote Transducer) communication. The value from 0 to 63 could be set and default is 0.

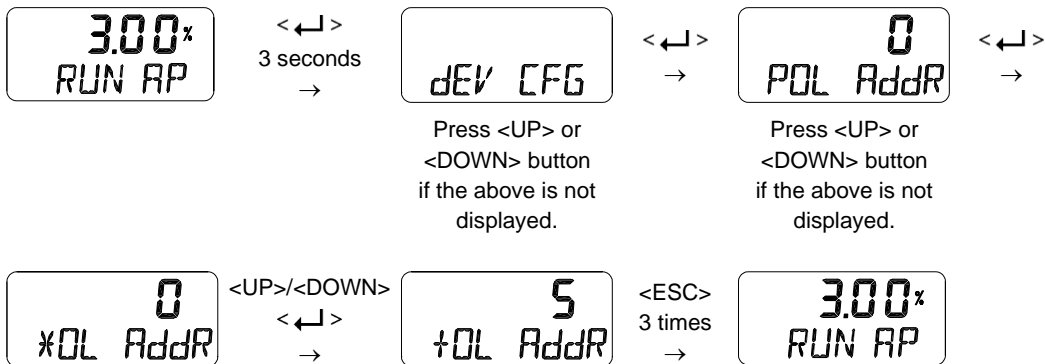

9.11.7 Factory Reset (dEFAULT OFF / on)

This function initializes all parameters stored in the positioner to initial factory setting. In the dEFAULT mode, press the Enter button to enables ON/OFF setting and then pressing Enter button for approximately 3 seconds changes the dEFAULT mode from OFF to "on". Additional pressing of Enter button resets all parameters to initial factory state.



**Pay attention when using this mode as all the parameter values will be changed to the factory settings.**

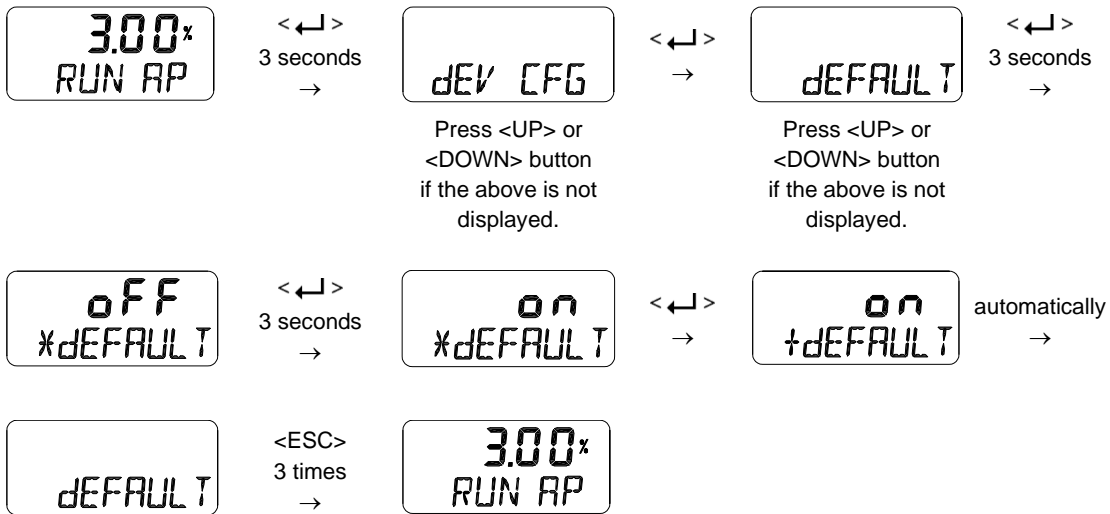

9.11.8 Positioner Self-Test (SELFTEST)

This function is used to diagnose the operation of the memory (RAM or NVM) inside the positioner. If no error is found during SELFTEST, the SELFTEST menu is displayed after FINISH is displayed, and if abnormalities are detected, the message "SEt / NVMW" is displayed.

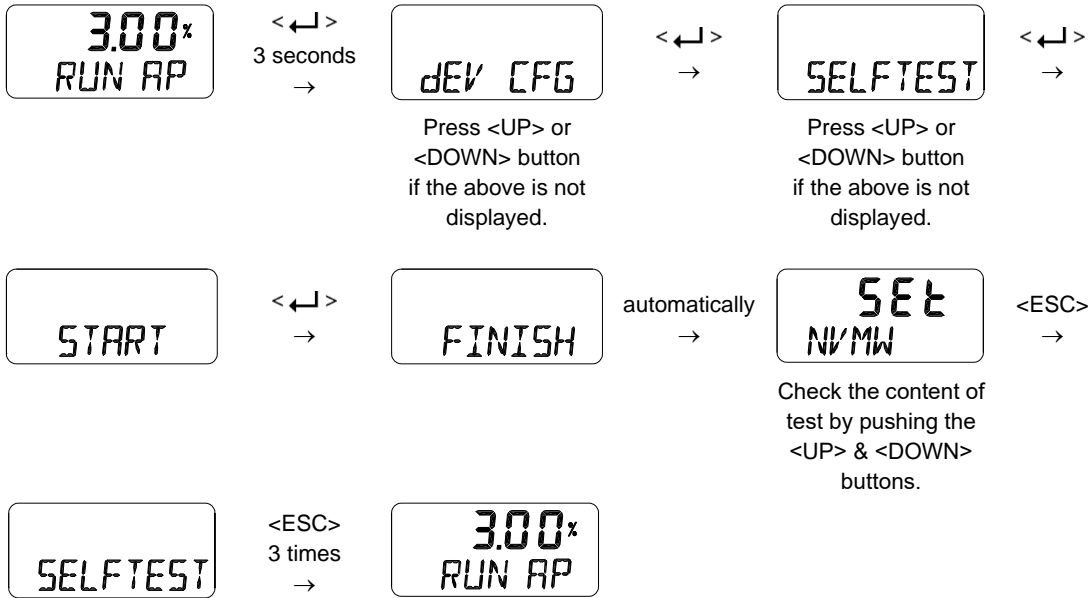

# Diagnostic message



If the abbreviation displayed at the top line is "Set", it means the event has been created, and if it is "CLr", the message has been cleared. NVMW at the bottom is an alarm message that has occurred. See "9.15 Status and Alarm Code" for alarm details.

## 9.12 Diagnosis Mode (DIAGNd)

Followings are the values changeable at the DIAGNO Mode.

- 1) Default Alarm Settings
- 2) Process Status (PS)
- 3) Device Status (dS)
- 4) View Monitoring Counts (VI CNTS)
- 5) Diagnostic Limit Configuration (LIMIT CFG)
- 6) Reset Alarm Status (RST ALRM)
- 7) View Event Log (EVT LOG)
- 8) Partial Stroke Test Record (View PST Result Record, PST RSLT)
- 9) PST Configuration (PST CFG)
- 10) Run PST (PST NOW)
- 11) Periodic PST Test (PST Schedule, PST SChd)

### 9.12.1 Default Alarm Settings

The table below shows the initial values set at factory for handling the positioner status or associated process conditions. Each status or alarm is set to one of the Failure, Out of Specification, Maintenance Required, or Functional Check at factory, so that the corresponding NE107 symbol is displayed when a specific alarm occurs. This setting is not user-reconfigurable. As shown in the table below, the status / alarms that can be manually reset without removing the cause are Auto Calibration Running, Critical NVM Fail, Non-Critical NVM Fail, PST Fail and Auto Calibration Fail. The two alarms below can be activated even by using the LCD screen and button without intervention of DD or DTM.





- Travel High Limit, Travel Low Limit

**Note 1. NE107 signal is not reconfigurable.**

Status / Alarm	Default setting	Default NE107 signal	Resettable manually when alarm occurred?
Local Operation Active	<b>Enable</b>	Functional Check	No
Auto Calibration Running	<b>Enable</b>	Functional Check	Yes
PST Running	<b>Enable</b>	Functional Check	No
Position Sensor High Limit	<b>Enable</b>	Out of Specification	No
Position Sensor Low Limit	<b>Enable</b>	Out of Specification	No
Critical NVM Fail	<b>Enable</b>	Failure	Yes
Non Critical NVM Fail	<b>Enable</b>	Failure	Yes
Travel High Limit	Disable	Out of Specification	No
Travel Low Limit	Disable	Out of Specification	No
Deviation Timeout	<b>Enable</b>	Out of Specification	No
PST Fail	<b>Enable</b>	Failure	Yes
Travel Cutoff High Limit	<b>Enable</b>	Out of Specification	No
Travel Cutoff Low Limit	<b>Enable</b>	Out of Specification	No
Not Calibrated	<b>Enable</b>	Maintenance Required	No
Auto Calibration Fail	<b>Enable</b>	Maintenance Required	Yes
Loop Current Low Limit	<b>Enable</b>	Failure	No

9.12.2 Process Status (PS)

The status of the current process is indicated as GOOd, NE107 symbol, and abbreviation for alarm.

NE107 symbols	Abbreviation	Function
None	PS GOOd	Good
	PS FAIL	Failure
	PS FUNC	Functional Check
	PS OUTS	Out of Specification
	PS MNTR	Maintenance Required



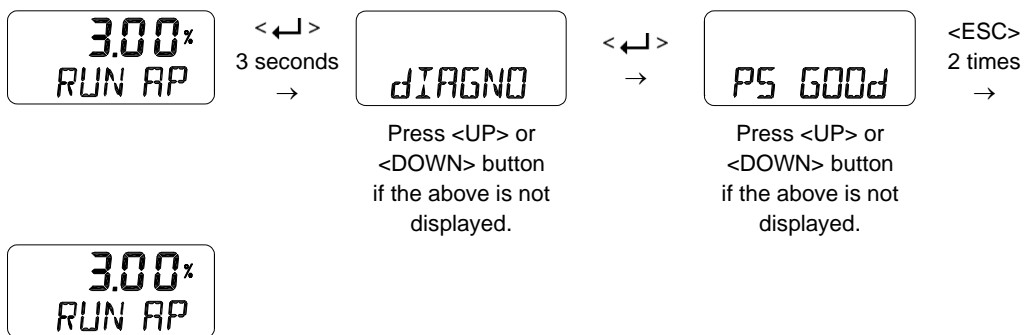

The table below shows the type of the process status or alarm and its abbreviations. See 9.15 Status and Alarm Code for the details of each alarm.

Process Alarm	Abbreviation
Travel High Limit	TVLH
Travel Low Limit	TVLL
Deviation Timeout	dVTO
Travel Cutoff High Limit	TVCH
Travel Cutoff Low Limit	TVCL
Loop Current Low Limit	LPCL



9.12.3 Device Status (dS)

The status of the current device is indicated as GOOd, NE107 symbol, and abbreviation for alarm.

NE107 symbols	Abbreviation	Function
None	dS GOOd	Good
	dS FAIL	Failure
	dS FUNC	Functional Check
	dS OUTS	Out of Specification
	dS MNTR	Maintenance Required

The table below shows the type of the device status or alarm and its abbreviations. See 9.15 Status and Alarm Code for the details of each alarm.

Device Alarm	Abbreviation
Loop Operation Active	LOPA
Auto Calibration Running	CALR
PST Running	PSTR
Position Sensor High Limit	PSNH
Position Sensor Low Limit	PSNL
Non-Critical NVM Fail	NVMW
Not Calibrated	NCAL
Auto Calibration Fail	CALF
PST Fail	PSTF



9.12.4 View Monitoring Counts (VI CNTS)

It is used to just view the accumulated data information for valve movement up to now.

Counter Name	Abbreviation [unit]	Function
Cycle Count	CYCL CNT	The accumulated number of times the valve has changed its direction. It is accumulated only when the valve change direction while Cycle Count Deadband is exceeded.
Travel Accumulator	TVL ACUM [%]	The total valve travel accumulated whenever Travel Accumulator Deadband is exceeded.
Operating Count	OPER CNT	Total number of input change applied to I/P converter.
Fully Open Count	FOP CNT	The accumulated number of times the valve has been fully open.
Fully Closed Count	FCL CNT	The accumulated number of times the valve has been fully closed.

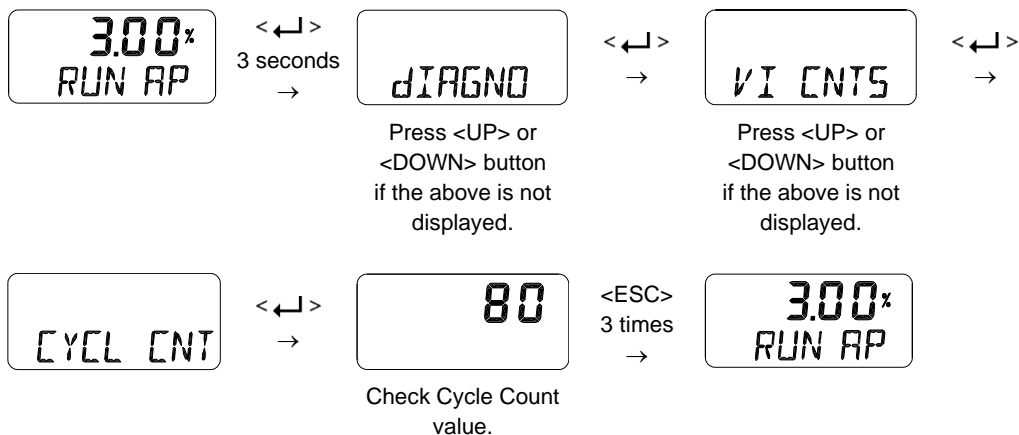

9.12.5 Diagnostic Limit Configuration (LIMIT CFG)

This configuration is used to set the upper or lower limit that is generated by the Travel High Limit Alarm and Travel Low Limit Alarm. Even if this condition is met, the corresponding alarm will not be triggered if the alarm(s) is not enabled.

Upper / Lower Limit or Enable	Abbreviation [unit]	Description
Travel High Limit	TVL HI [%]	Alarm is triggered if the valve stroke exceeds TVL HI. The initial factory setting is 100%.
Travel Low Limit	TVL LO [%]	Alarm is triggered if the valve stork is lower than TVL LO. The initial factory setting is 0 %.
Travel High Limit Alarm Enable	AL TVLH	These are used to set "on" or "off" for each alarm. When set to oFF, the alarm does not occur even if the conditions are met. All the initial factory settings are oFF.
Travel Low Limit Alarm Enable	AL TVLL	

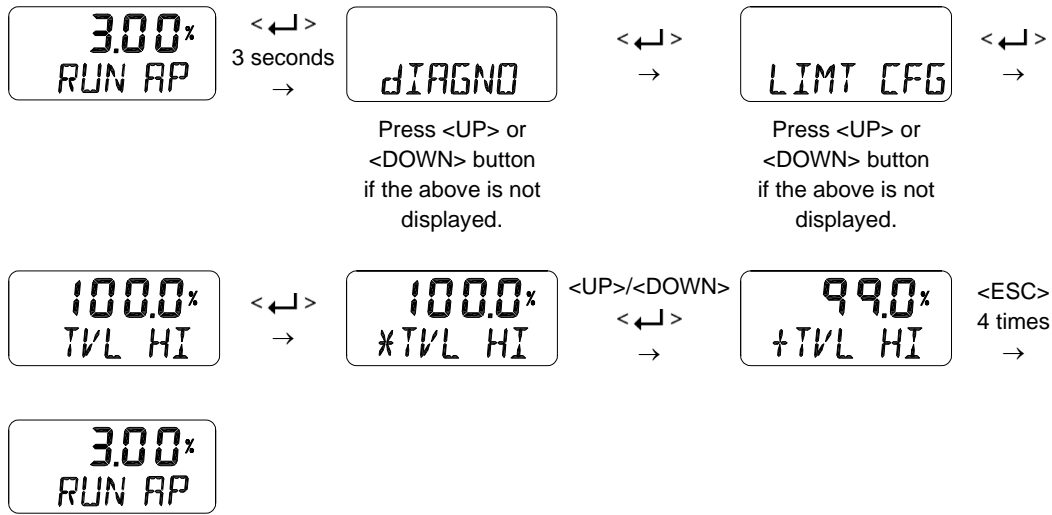

9.12.6 Reset Alarm Status (RST ALRM oFF / on)

The alarm is automatically released when the cause of the alarm is removed. For example, if the Partial Stroke Test fails or Auto Calibration fails, use this function to release the alarm.

Below is an alarm list that can be released using the RST ALRM function.

- 1) Auto Calibration Running
- 2) Non-Critical NVM Fail
- 3) PST Fail
- 4) Auto Calibration Fail

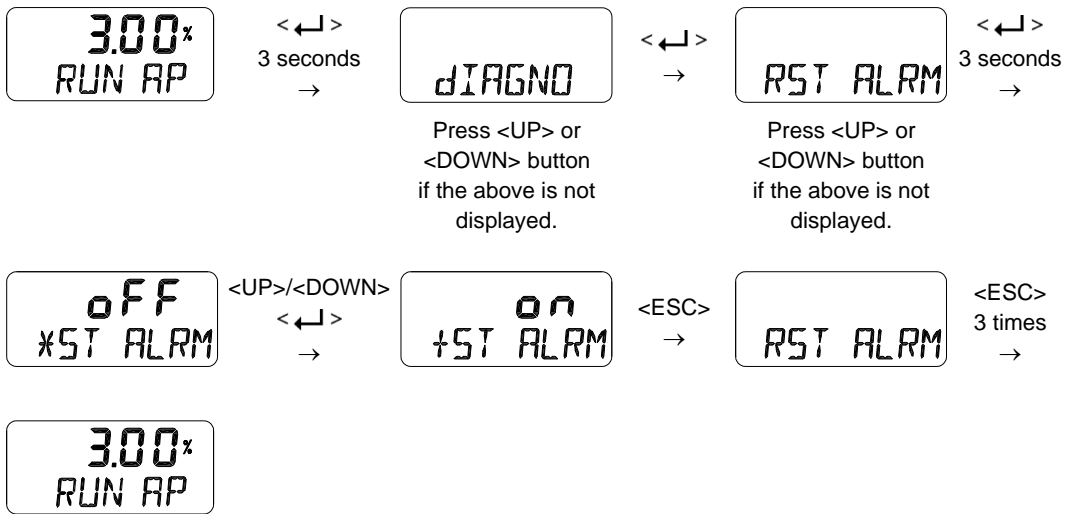

9.12.7 View Event Log (EVT LOG)

This is used to show the 20 most recent events that occurred in operation. Record 0 is the most recent of the 20 events and Record 19 is the oldest event. The event detail shows the time when the event occurred (EVT TIME) as well as the content of the event (EVT INFO). See 9.15 Status and Alarm Codes for an abbreviation and description of the event details.

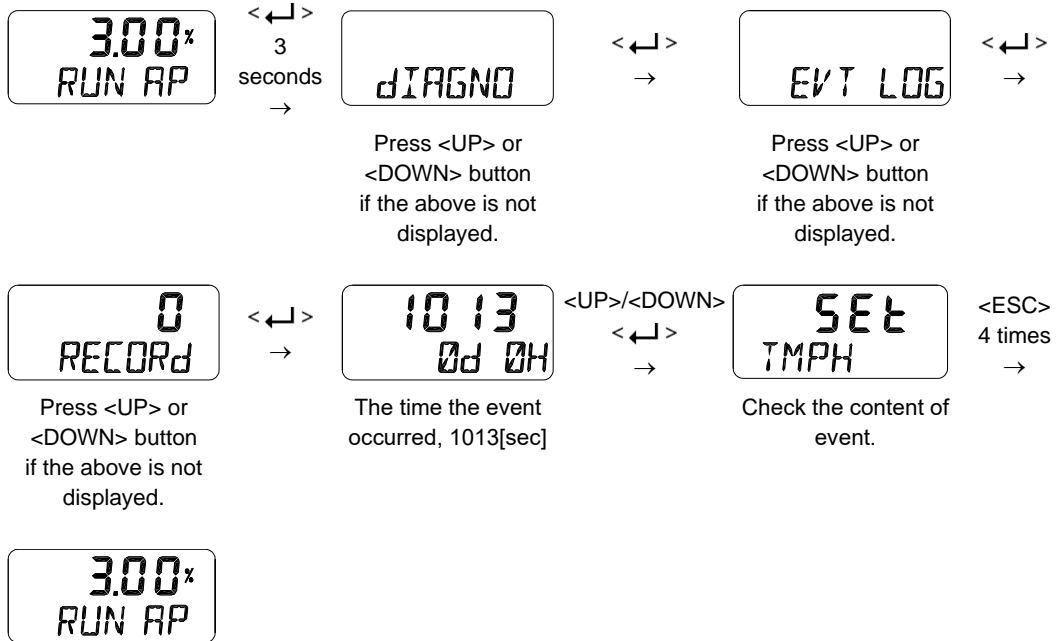

# Event Message Description



The "SEt on the upper section of screen shows that a specific event has occurred, while the "CLr" means that the event has been removed. The "TMPH" displayed on the bottom section indicates an abbreviation for the alarm.

9.12.8 Partial Stroke Test Record (View PST Result Record, PST RSLT)

This is used to show information about the 10 most recent Partial Stroke Tests performed. Record 1 is the most recent of the 10 PST histories, and Record 10 is the result of the oldest PST operation. The response time (RT), response code (RC), and dead time (dT) after the PST operation are also shown. Response time represents the time to reach the target position from the PST start, and deadtime indicates the time from the start of the PST command to the moment the valve starts to move. The table below describes the response codes.

Name of RC	Response Code (RC)		Description
Pass	PASS	1	Pass
Out Of Tolerance	OOT	2	Out of Tolerance : When PST is executed, the AP (actual position) is out of PST tolerance compared to the PST start position value.
PST Time Out	PSTO	3	Time Out : Aborted if the AP fails to move to the Target Position within PST Limit Time during PST execution.
Abort	AbOT	4	Abort, but reserved
Hunting	HUNT	5	Hunting occurs during the test.
Abnormal Shutdown	AbSd	6	Abnormal Shutdown : An unexpected problem occurred during the test.
Loop Current Low	LPCL	256	PST execution is stopped due to a change in the input signal (0.8 mA (5%) or more).
Stop By Digital Input	STdl	512	Stopped by Digital Input Function (dIF)

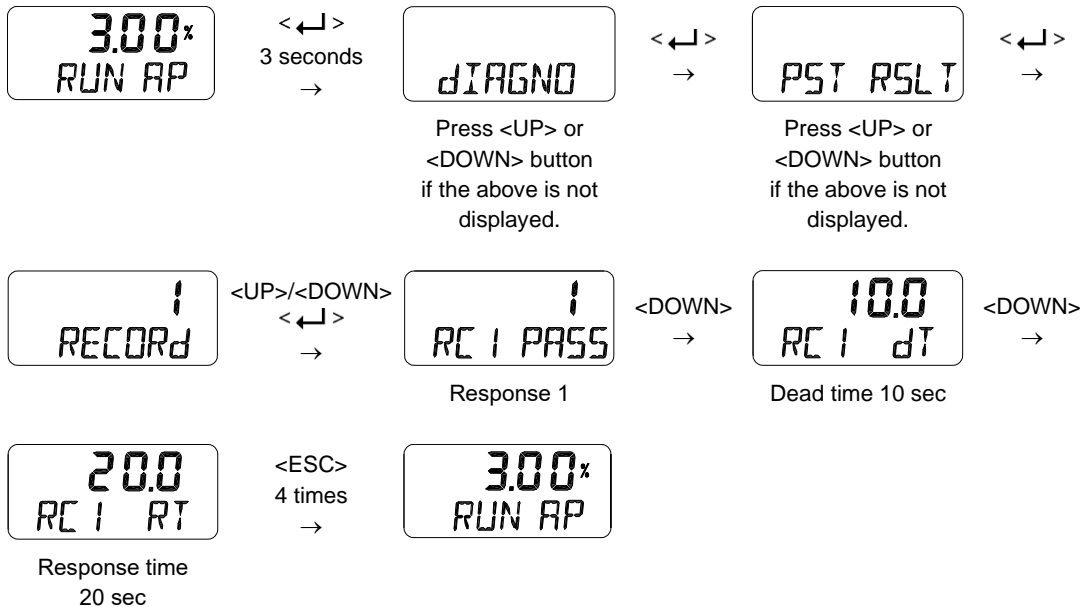

9.12.9 PST Configuration (PST CFG)

Parameter names	Abbreviation [unit]	Description
PST Interval	INTERVAL [days]	Sets time interval PST is triggered. Initial factory setting is 365 days.
PST Start Position	START PO [%]	Sets the start position to launch PST. Initial factory setting is 100 %.
PST Tolerance	TOL [%]	The allowable tolerance for the start position. PST Failure alarm is triggered as Out of Tolerance(OOT) when actual position exceeds the tolerance. Initial setting is 5 %.
PST Target Position	TARGET [%]	Target position. Initial factory setting is 90 %.
PST Hold Time	HOLD TM [sec]	Sets hold time after target position ( $\pm 2$ %) is reached Initial factory setting is 5 sec.
PST Limit Time	LIMIT TM [sec]	PST Failure alarm is triggered as Limit Time Over (LTO) when target position is not reached within LIMIT TM after starting PST. Initial factory setting is 10 sec.
PST Ramp Up Rate	RAMP UP [%/sec]	Sets ramp rate when the valve moves from the target position to the start position. Initial factory setting is off.
PST Ramp Down Rate	RAMP dN [%/sec]	Sets ramp rate when the valve moves from the start position to the target position. Initial factory setting is off.
Remaing PST Time	NEXT PST [days.hrs]	Based on the current time, the remaining time to start PST is displayed by Days and Time.

Graph below shows PST target position (TP) and actual position (AP) when applying PST Start Position 100 %, Target Position 90 %, Hold Time 10 sec, PST Ramp up Rate 0.5 %/sec, PST Ramp down Rate 0.5 %/sec.



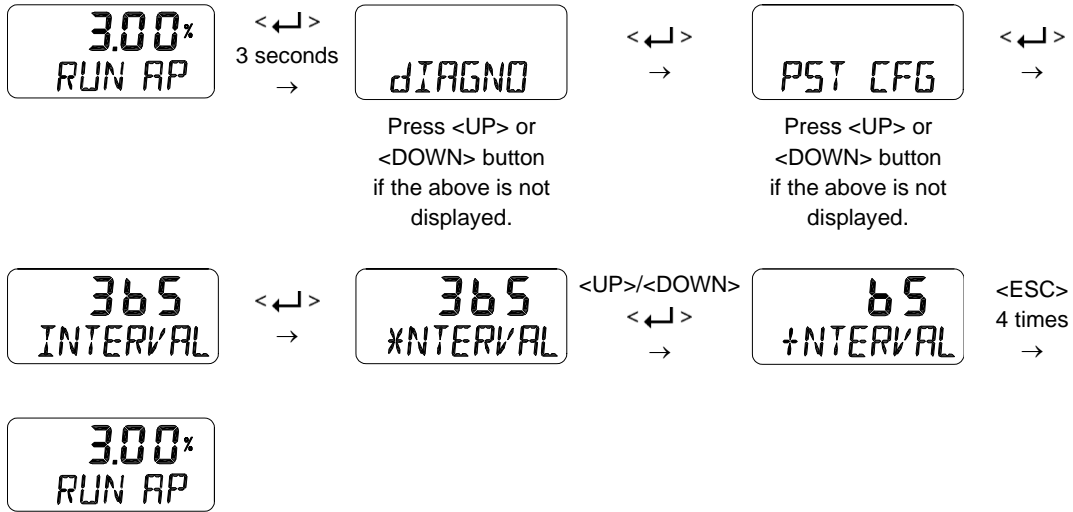

### 9.12.10 Run PST (PST NOW)

PST NOW is used to perform Partial Stroke Test promptly in accordance with the conditions set in 9.12.9.

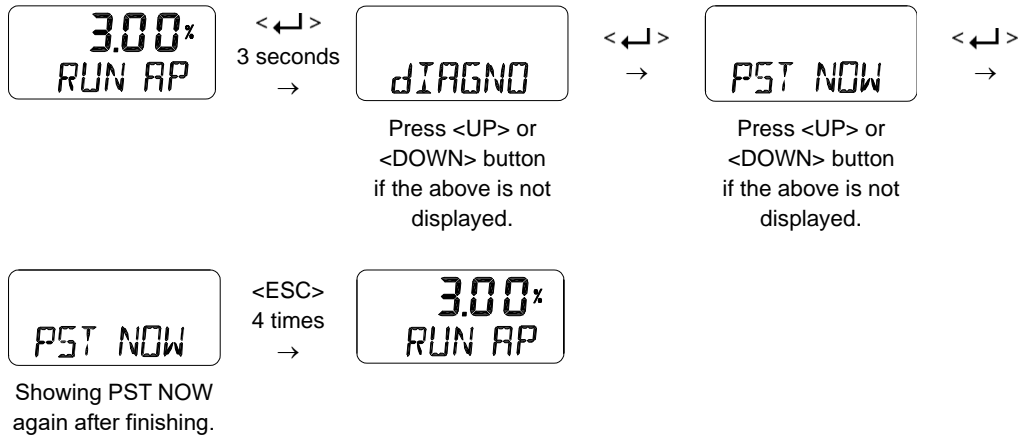

9.12.11 Periodic PST Test (PST Schedule, PST SCHd oFF / on)

When PST SCHd is set to ON, the Partial Stroke Test is executed regularly under the conditions set in 9.12.9 above. For example, PST is performed every 365 days when PST Interval is set to 365 days. The initial factory setting is OFF.

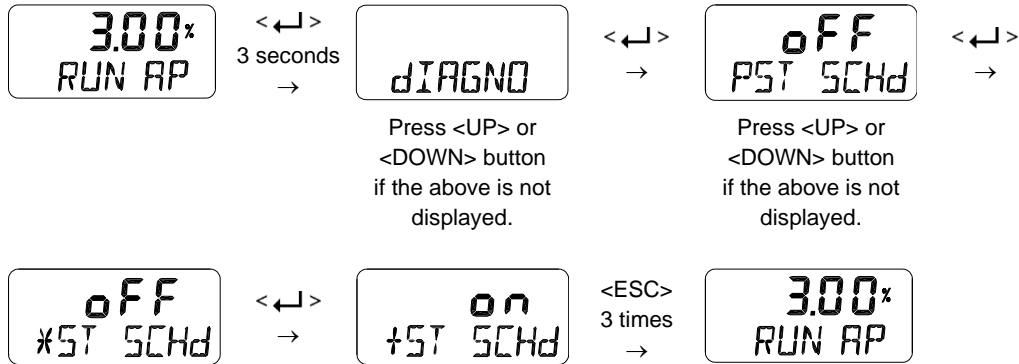

9.13 Position information (INFO)

The diverse Positioner information is provided in the INFO Mode.

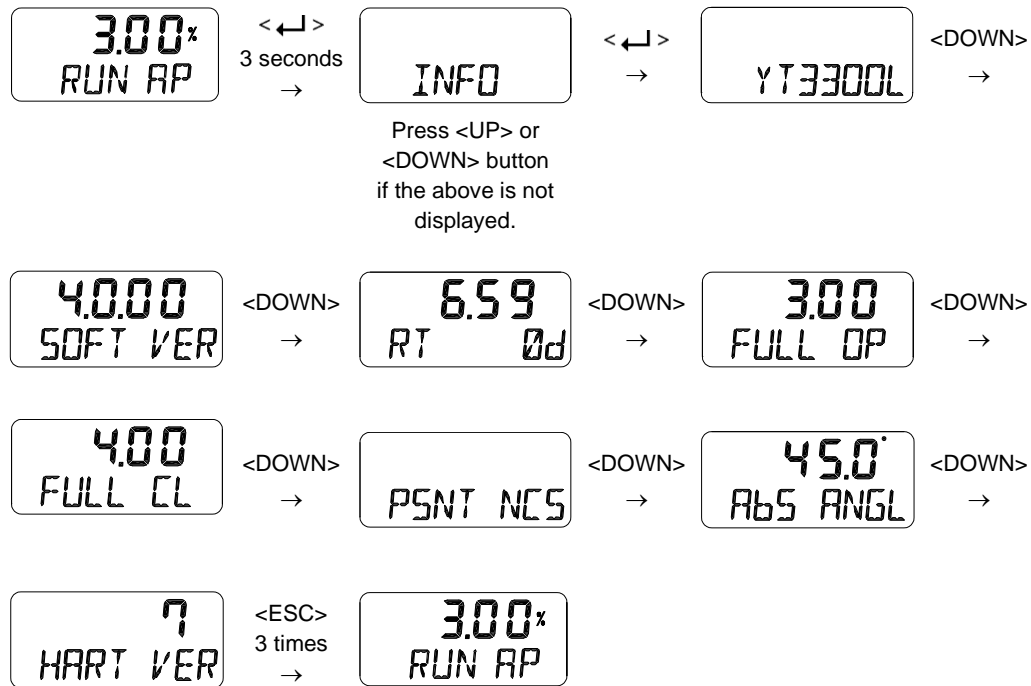

LCD display	Description
<b>YT3300L</b>	Model Name
<b>4.0.00 SOFT VER / 2022JA31</b>	Software Version [SOFT VER] "4.0.00" Software Input date : "2022-01(JA)-31" (January JA, February FB, March MR, April AR, May MY, June JN, July JL, August AG, September SP, October OT, November NV, December DC) At SOFT VER status if <← > button is pressed, the date will be displayed and then if <← > button is pressed again, SOFT VER is displayed again.
<b>4.18 RT      0d</b>	Run Time [RT] Total usage time of the product Upper "4.18" indicates 4 hours and 18 minutes. Lower "0d" indicates days used. Interval to store time is one hour.
<b>3.12 FULL OP</b>	Upward Full Stroke Time [FULL OP] This value is stored automatically after executing AUTO 2 calibration, and indicates the time in seconds it takes for the valve to fully open from fully closed.
<b>2.97 FULL CL</b>	Downward Full Stroke Time [FULL CL] This value is stored automatically after executing AUTO 2 calibration, and indicates the time in seconds it takes for the valve to fully closed from fully open.
<b>PSNT NCS</b>	Position Sensor Type [PSNT] Potentiometer [PTN] Non-Contact Sensor [NCS]
<b>AbS ANGL</b>	Absolute Position in Angle [ABS ANGL].
<b>HART VER</b>	HART Protocol Revision [HART VER]

9.14 Error codes during automatic calibration

The error detected during the automatic calibration is displayed on LCD especially when the positioner may become out of control, may malfunction or may become poor in precision. Once it is detected, the auto calibration is aborted.

Error code		Error content and cause	Action
CHK AIR	-7	➤ Indicated when the valve is not moving in "Full Open" direction during auto calibration.	➤ Check if pneumatic pressure is being supplied normally to the positioner.
	-9	➤ Indicated when the valve is not moving in "Full Close" direction during auto calibration.	
	-10	➤ Indicated when there is no response in torque motor.	
	-12	➤ Indicated when oscillation happens in steady state during SCAN 1 phase of auto calibration.	➤ Check for leakage from output port of the positioner and related to piping line.
CHK LINK	-8	➤ Indicated when the movable range of the Feedback lever is too narrow(below 10°).	➤ Linear : Check if the feedback lever is properly installed. Move and re-install the positioner to stem of actuator in order to make the angle use of the feedback lever larger than current use angle. ➤ Rotary: Check if the main shaft of the positioner is properly installed. In the case of Namur, the horizontal straight part of the main shaft of the positioner must be well inserted into the slotted groove of the actuator stem.

9.15 Status and Alarm Code

Refer to the table below to check the status and alarm codes that can be displayed on LCD screen or HART monitor, and then take the appropriate action.

**Note 1. Any status or alarms assigned to one of NE107 signals at factory is not newly assignable.**

Alarm Code	Abbreviation	Status / Alarm name	Description or proposed actions
0	LOPA	Local Operating Active	It indicates the positioner is being operated by manual operation.
1	CALR	Auto Calibration Running	It is active when auto-calibration is in progress.
2	PSTR	PST Running	It is active when Partial Stroke Test is in progress.
4	PSNH	Position Sensor Hi Limit	Position sensor is out of range. Check the installed state if it happened during operation.
5	PSNL	Position Sensor Lo Limit	
7	NVMW	Non-Critical NVM Defect	It is active if there is a failure associated with NVM (Nonvolatile Memory). Initialize the positioner using Default function and then AUTO 2 calibration. If it is repeated, replace the electronics board by contacting the manufacturer or manufacturer's representative.
13	TVLH	Travel Hi Limit	It is active when the travel exceeds Travel Hi Limit.
14	TVLL	Travel Lo Limit	It is active when the travel falls below Travel Lo Limit.
15	dVTO	Deviation Time Out	It lasts more than 60 seconds with the deviation between the target location and the actual location out of 5%. The deviation time 60 seconds and the deviation 5% are not changeable but fixed. Check if there is no problem with the friction of valve/actuator, pneumatic leaks, insufficient supply pressure.
16	PSTF	PST Failure	It is active when Partial Stroke Test has failed. Remove the cause of the failure after checking the response code of the PST.
23	TVCH	Travel Cutoff Hi Limit	It is active when the travel exceeds the available high stroke of the valve/actuator. The available stroke is already set during auto calibration. The event is not created when Tight Shut Open is used. Aging of the valve / actuator assembly or problem in the positioner sensor.
24	TVCL	Travel Cutoff Lo Limit	It is active when the travel is below the available low stroke of the valve/actuator. The available stroke is already set during auto calibration process. The event is not created when Tight Shut Close is used. Aging of the valve / actuator assembly or problem in the positioner sensor.

Alarm Code	Abbreviation	Status / Alarm name	Description or proposed actions
28	NCAL	Not Calibrated	It is active when auto-calibration has not done after installation. Perform AUTO 2 calibration after checking if the installed state is good.
29	CALF	Auto Calibration Failure	It is active when auto-calibration has failed. Retry auto-calibration after checking if there is no problem with installed state such pneumatic leaks, lever position and others.
37	LPCL	Loop Current Lo Limit	It is active if the input current falls below 3.8 mA.
145	VARA	Device Variable Alert	It is active when one of the internal variables are out of range.
144	MNTR	Maintenance Required	It is active when more than one of alarms assigned to "Maintenance Required" have happened. Remove the cause of the alarm after checking it.
147	FAIL	Failure	It is active when more than one of alarms assigned to "Failure" have happened. Remove the cause of the alarm after checking it.
148	OUTS	Out of Specification	It is active when more than one of alarms assigned to "Out of Specification" have happened. Remove the cause of the alarm after checking it.
149	FUNC	Function Check	It is active when more than one of alarms assigned to "Functional Check" have happened. Remove the cause of the alarm after checking it.
-	OVER CUR	Over Current	The input current exceeds 24mA.

## 11 Main Software Map

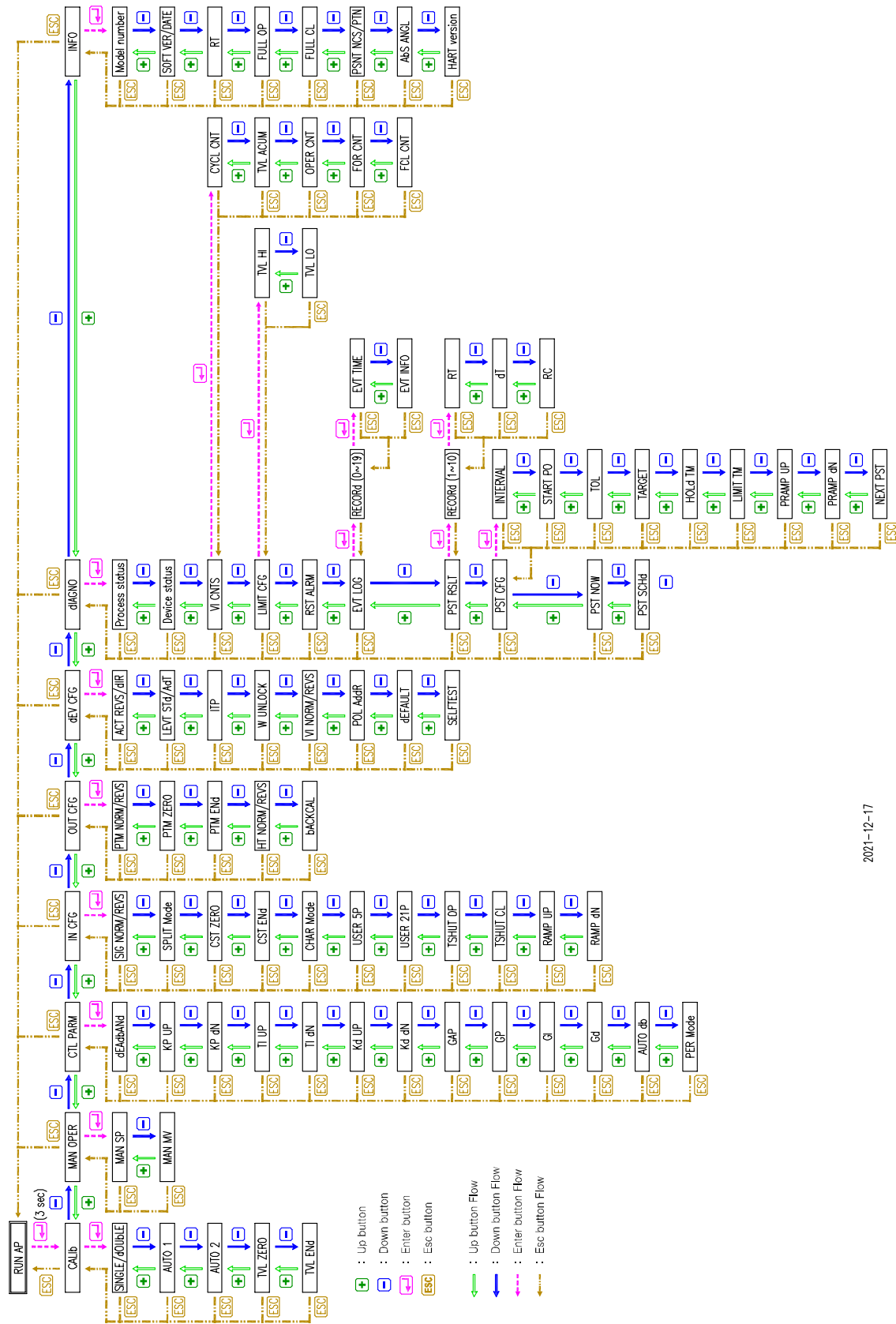

2021-12-17

# ایمن کنترل سپهند

مرکز تخصصی طراحی، فروش و مشاوره

■ تجهیزات ابزار دقیق ■ تجهیزات ایمنی ■ تجهیزات ضد انفجار



Honeywell



آدرس: تهران - خیابان سمیه - بعد از تقاطع بهار - ساختمان ایرج - پلاک ۶۳ - واحد ۱۱

۰۹۳۹۵۱۸۸۱۶۴

۰۲۱-۸۸۳۴۱۴۸۳

۰۲۱-۸۶۰۷۲۸۲۳



IMEN  
CONTROL  
SAHAND

---

**Manufacturer: Rotork YTC Limited**

Address: 81, Hwanggeum-ro, 89 Beon-gil, Yangchon-eup, Gimpo-si, Gyeonggi-do, South Korea

Postal code: 10048

Tel: +82-31-986-8545

Fax: +82-70-4170-4927

Email: [ytic.sales@rotork.com](mailto:ytic.sales@rotork.com)

Homepage : <http://www.ytc.co.kr>

Issued : 2023-05-18

---

Copyright © Rotork YTC Limited. All Rights Reserved.